







Thank you for purchasing this quality product. Be sure to check all packing material carefully for small parts that may have come loose inside the carton during shipment.

Hardware kit (1966-42KDP46)			
No		Description	Q'Ty
A		Lock Washer 5/16"	13 pcs
B		Flat Washer 5/16"	13 pcs
C		Long Bolt 1/4"x 3"	4 pcs
D		Medium Bolt 1/4"x 2"	6 pcs
E		Short Bolt 1/4"x 1.5"	3 pcs
F		Allen Key	1 pc

Key Parts			
No	Code	Description	Q'Ty
1	1966-42KDP40	Chair Back	1 pc
2	1966-42KDP41	Complete Seat	1 pc
3	1966-42KDP42	Front Legs	2 pcs
4	1966-42KD42M	Middle Front Leg	1 pc
5	1966P01F	Floor Glide	6 pcs

FABRIC CARE INSTRUCTION REGULAR CARE

Clean with shampoo, foam, or dry cleaning solvents as desired. Do not saturate with liquid. Pile fabrics may require brushing to restore appearance.

Cushion covers should not be removed and dry cleaned.

FABRIC CONTENT: 100% Polyester; Cleaning code "WS"

STEP 1

- Carefully lay chair Back flat on a smooth flat surface to prevent scratches.

- Attach Complete Seat (2) to Chair Back (1) by inserting a Flat Washer (B), Lock Washer (A) and Short Bolt (E) into each of the hole on the back of the seat. Tighten screws with provided Allen Key by turning clockwise until secure. (See Detail A).

- Insert a Flat Washer (B), Lock Washer (A) and Long Bolt (C) into each of 2 holes in the Complete Seat corner. Tighten screws with provided Allen Key. (See Detail B)

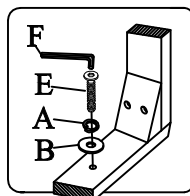

DETAIL A

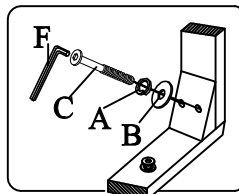

DETAIL B

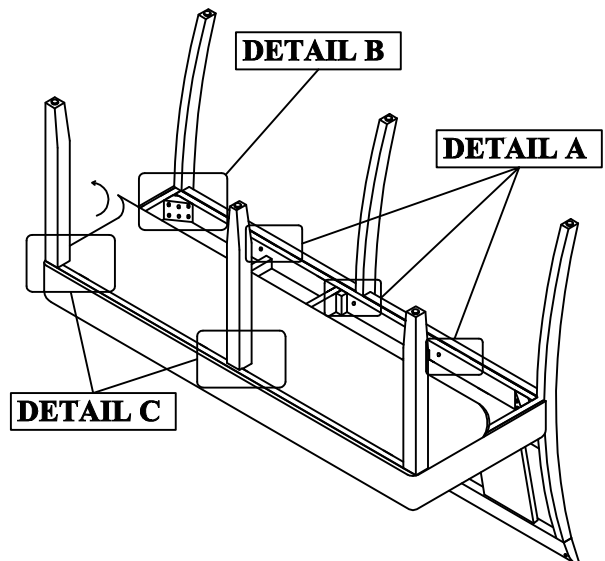
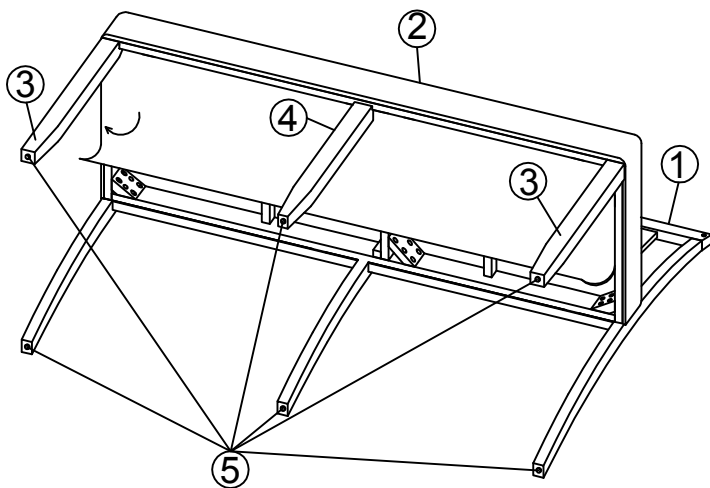

STEP 2

- Carefully turn chair upside down and attach Corner Front Legs to the front corner of the Seat and the middle leg to the middle of the seat with a Flat Washer (B), Lock Washer (A) and Medium Bolt (D). (See detail C).

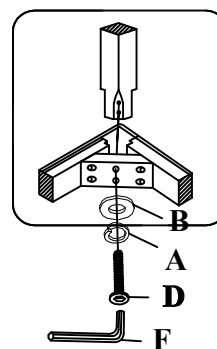

DETAIL C

