

5-Pack Hardware Kit (922P01)

Ltr	Qty	Description
A	8 pcs	Flat Washer
B	8 pcs	Lock Washer
C	8 pcs	Nut Øm6
D	1 pc	Key Wrench

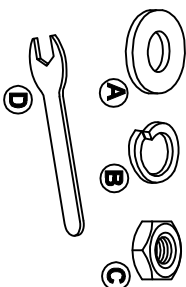
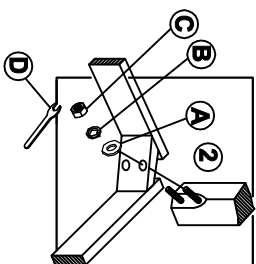
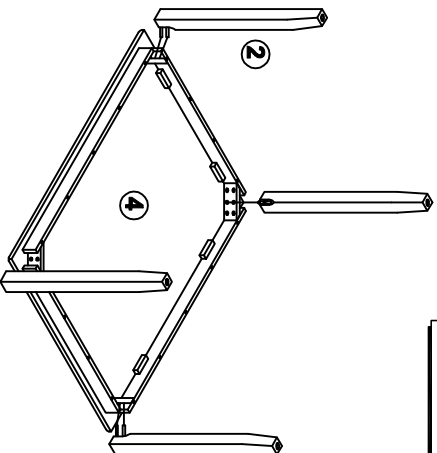

Table Parts Key

No	Code	Qty	Description
1	922P01FT	4 pcs.	Table/Floor Glide
2	922P02	4 pcs.	Leg
3	922P26	4 pcs.	Corner Block
4	922P24	1 pc.	Table top



Detail A



STEP 1

- Carefully lay table top upside down on a smooth flat surface to prevent scratches.
- Affix a leg to each corner of the table top as shown in Detail A using a flat washer, lock washer and nut.
- Once all legs are in place, fully tighten the nuts

MADE IN VIET NAM

5-Pack Hardware Kit (922P46)

Ltr	Qty	Description
A	44 pcs.	Flat Washer
B	44 pcs.	Lock Washer
C	16 pcs.	Nut Øm6
D	1 pc.	Key Wrench
E	16 pcs.	Long KD. Bolt Øm6x 75mm.
F	12 pcs.	Short KD. Bolt Øm6x 40mm.
G	1 pc.	Allen Wrench

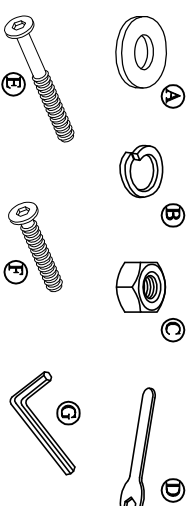

Chair Parts Key

No	Code	Qty	Description
5	922P01FC	16 pcs.	Chair Floor Glide
6	922P40	4 pcs.	Chair Back
7	922P41	4 pcs.	Complete Seat
8	922P42	8 pcs.	Front Leg

* Quantities noted are for a total of four chairs.

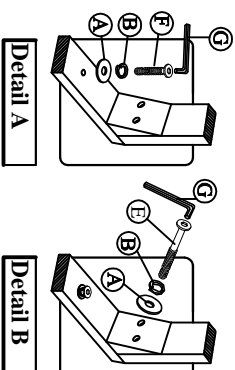

Detail A

Detail B

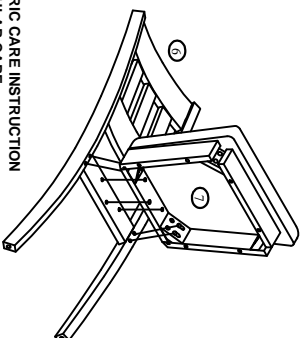

FABRIC CARE INSTRUCTION
REGULAR CARE: Wipe gently using a soft damp cloth and mild detergent. DO NOT SATURATE.
FABRIC CONTENT: 100% PU vinyl; Cleaning code "W"

STEP 2

- Carefully turn chair upside down and affix each Leg to the front corner of the complete seat, as shown in Detail C, using a flat washer, lock washer, and nut.
- Turn chair upright and make sure it is level before fully tightening all bolts and nuts.
- Be sure to tighten all screws prior to using chair.

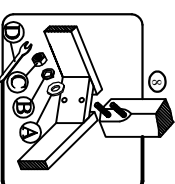

Detail C

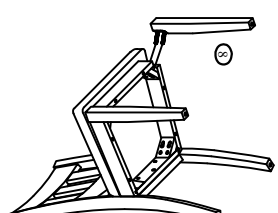

STEP 1

- Carefully lay chair back flat on a smooth flat surface to prevent scratches.
- Affix the complete seat to chair back, as shown in Detail A, using a flat washer, lock washer and short KD bolt.
- Secure complete seat to chair back corners, as shown in Detail B, using a flat washer, lock washer and long KD bolt. - Tighten screws with provided Allen Wrench.