







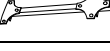

Parts List				
Item	Figure	Part No.	Q'ty	Description
(1)		785-6P51	1PC	Table Top
(2)		785-6P08	1PC	Bottom Shelf
(3)		785-6P02	4PCS	Legs
(4)		P01F	0PCS	∅ 1/4" Adj Glides

Hardware Kit (Part no. 785-1P01)				
Item	Figure	Spec.	Q'ty	Description
A		1/4" dia*3/4"	16 pcs	Allen Bolts
B		1/4" dia	16 pcs	Lock Washers
C		1/4" I.D.*19mm O.D.	16 pcs	Flat Washers
D		4mm*2.5"	1 pc	Allen Wrench

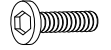
Please note: The following steps may need 2 persons to complete it.

STEP 1:

Please carefully place table top (Item 1) upside down on a soft clean surface. Carefully turn leg (Item 3) upside down and attach 3 legs to the table top with an Allen Bolt (A), Lock Washer (B) Flat Washer (C) loosely tighten with provided Allen Wrench (D).

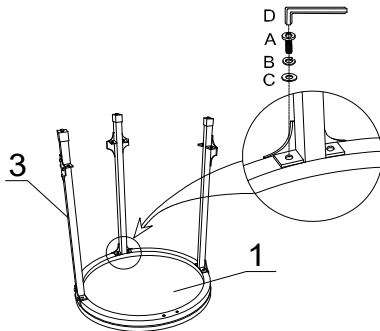

STEP 2:

Carefully turn the Bottom Shelf (Item 2) upside down and gently slide it in-between the 3 Legs; attach the shelf to the legs with an Allen Bolt (A), Lock Washer (B), and Flat Washer (C), loosely tighten with provided Allen Wrench (D).

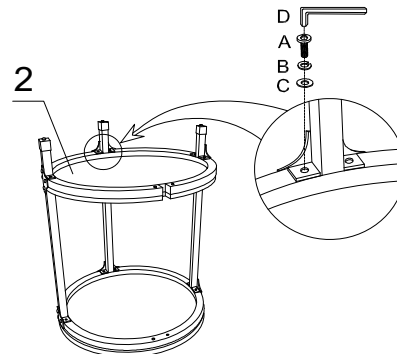

STEP 3:

Adjust all parts to the appropriate positions, attach the fourth leg and then tighten all Allen Bolts.

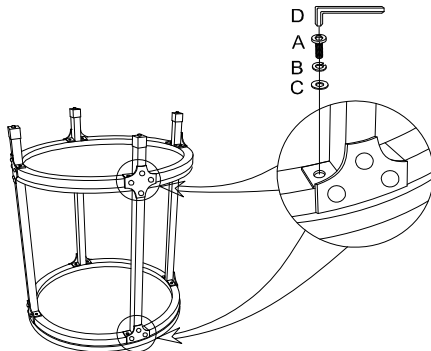

STEP 4:

Carefully turn the assembled table to the upright position.

