

Thank you for purchasing this quality product. Be sure to check all packing material carefully for small parts that may have come loose inside the carton during shipment.

Hardware kit (647-BS831KDP46)			
No		Description	Q'Ty
A		Hexa Nut Ø8	4 pcs
B		Lock Washer Ø8	11 pcs
C		Flat Washer Ø8	11 pcs
D		Long Bolt Ø6 x 80mm	4 pcs
E		Short Bolt Ø6 x 40mm	3 pcs
F		Allen Key	1 pc
G		Key Wrench	1 pc
H		Screw Ø4 x 38mm	6 pcs

Key Parts			
No	Code	Description	Q'Ty
1		Stool Back	1 pc
2	647-BS831KDP41	Complete Seat	1 pc
3	647-BS831KDP42	Right Facing Front Leg	1 pc
4	647-BS831KDP43	Left Facing Front Leg	1 pc
5	647-BS831KDP44	Right Facing Side Stretcher	1 pc
6	647-BS831KDP45	Left Facing Side Stretcher	1 pc
7	647-BS831KDP49	Front Stretcher	1 pc
8	647-BS831KDP01F	Floor glide	4 pcs

### STEP 1

- Carefully lay Chair Back flat on a smooth flat surface to prevent scratches.
- Affix Complete Seat to Chair Back by inserting a Flat Washer (C), Lock Washer (B) with Short Bolt (E) into each of the hole on the back rail of the seat, and Long Bolt (D) into each of 2 holes in the Complete Seat corners. (See Detail A & B).
- Tighten screws with provided Allen Key (F) by turning clockwise until secure

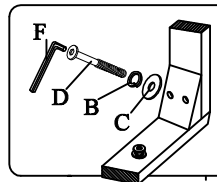

DETAIL B

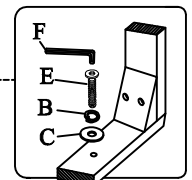
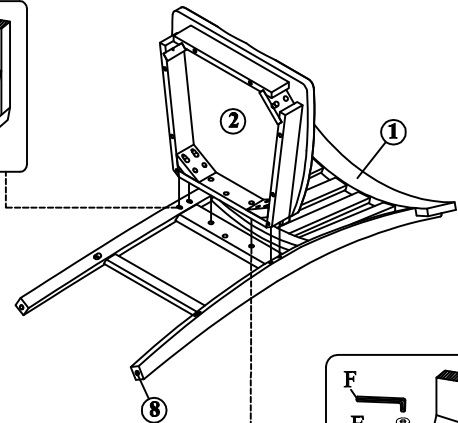

DETAIL A

### DETAIL D

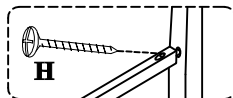

### STEP 2

- Carefully turn Chair upside down and affix each Leg to the front corners of the Complete Seat.
- Place Flat Washer (C), Lock Washer (B) and Nut (A) on for each bolt, using provided Key Wrench (G).
- Do not fully tighten the Nuts at this stage until all the parts are in position (See Detail C).
- Insert 2 Side Stretchers between the Front Legs, and insert the Front Stretcher between the Front Legs, fasten with Wood Screw using phillip-head screwdriver. (not provided).(See Detail D)
- Be sure to tighten all screws and nuts prior to using Chair.

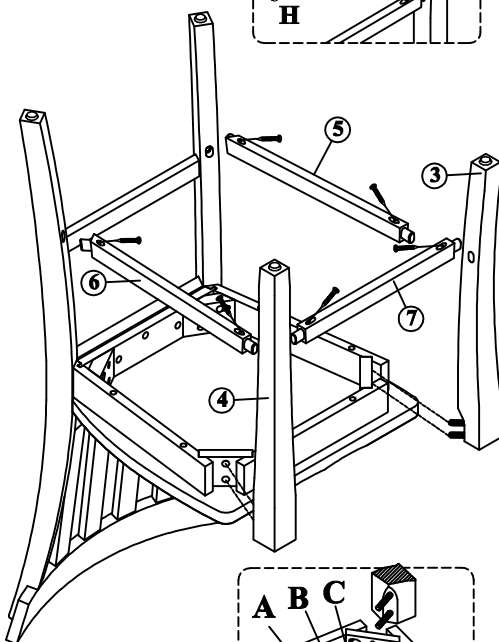

DETAIL C

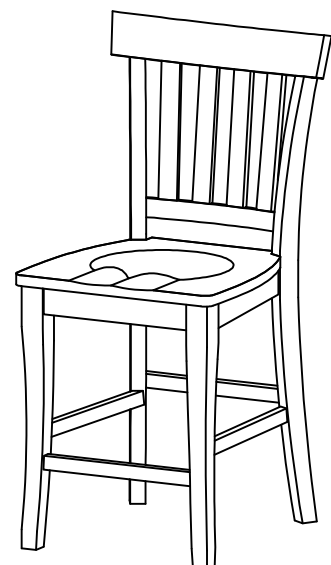
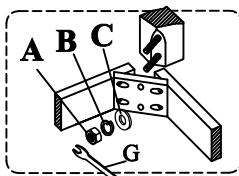

Merci d'avoir acheté ce produit de qualité. Soyez sûr de vérifier tout le matériel d'emballage avec soin pour petite part qui peut avoir été lâche à l'intérieur du carton pendant le transport.

Trousse de quincaillerie (647-BS831KDP46)			
No	Description	Q'Te	
A	Écrou Ø8	4 pcs	
B	Rondelle Frein Ø8	11 pcs	
C	Rondelle Plate Ø8	11 pcs	
D	Boulon Ø6 x 80mm	4 pcs	
E	Boulon Ø6 x 40mm	3 pcs	
F	Clé Hexagonale	1 pc	
G	Clé Principale	1 pc	
H	Vis Ø4 x 38mm	6 pcs	

Les pièces			
No	Code	Description	Q'Te
1	647-BS831KDP40	Dossier	1 pc
2	647-BS831KDP41	Siège	1 pc
3	647-BS831KDP42	Pied droite	1 pc
4	647-BS831KDP43	Pied a gauche	1 pc
5	647-BS831KDP44	Traverse droite	1 pc
6	647-BS831KDP45	Traverse gauche	1 pc
7	647-BS831KDP49	Traverse De Devant	1 pc
8	647-BS831KDP01F	Patin	4 pcs

### ÉTAPE 1:

- Placez soigneusement le dossier sur une surface plane et lisse pour éviter les rayures.
- Fixez le siège pour le dossier avec une rondelle plate (C), une rondelle frein (B) et un boulon court (E) dans chacun des trous à l'arrière du siège et le boulon long (D) dans chacun des 2 trous dans les coins de siège. (Détail A et B).
- Serrez les vis avec la clé Allen fournie en tournant dans le sens horaire jusqu'à sécurisé.

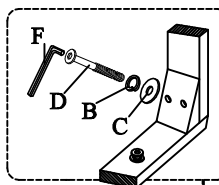

DÉTAIL A

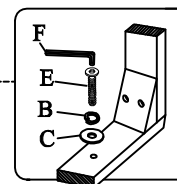
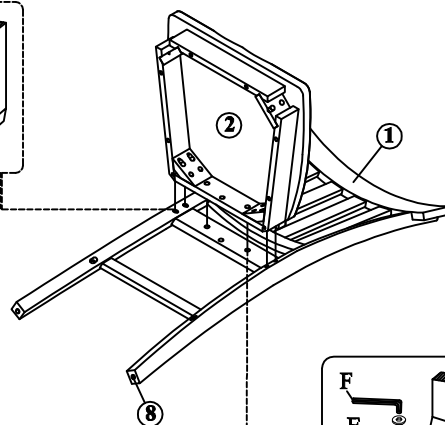

DÉTAIL A

DÉTAIL D

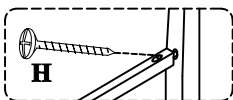

### ÉTAPE 2:

- Tournez avec précaution la chaise à l'envers et fixez chaque pied aux coins avant de la siège.
- Placer la rondelle plate (C), Rondelle (B) et l'écrou (A) sur chaque boulon, avec la clé fournie (G).
- Ne serrez pas complètement les écrous à ce stade jusqu'à ce que toutes les pièces sont en place (voir détail C).
- Insérez les deux traverses latérales entre les pieds avant et les pieds arrière. Insérez le traverses avant entre les pieds avant. Fixez avec les vis à bois et un tournevis philipshead. (pas inclus). (Détail D)
- Serrez bien toutes les vis et les écrous avant d'utiliser la Chaise.

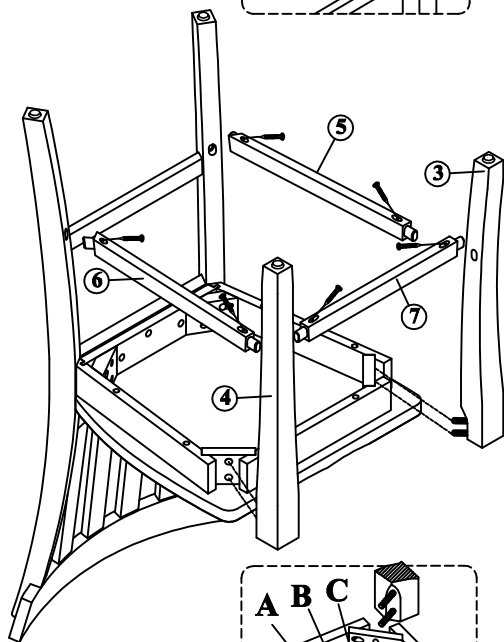

DÉTAIL C

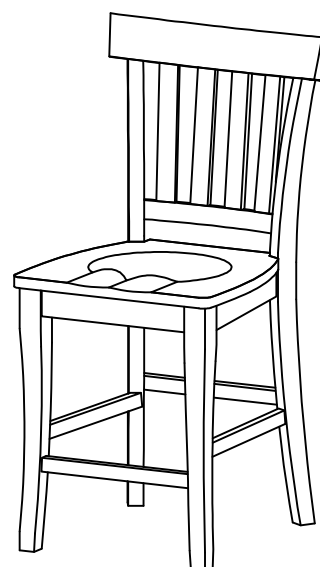
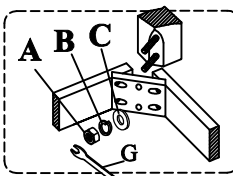

Gracias por comprar este producto de calidad. Por favor asegure que tenga todas las piezas en la caja, la partes pequeñas se pudieron haber movido de su lugar

Juego de Herramientas (647-BS831KDP46)			
Letra	Descripción	Cant'd	
A	 Tuerca Ø8	4 pzs	
B	 Anillo de Seguridad Ø8	11 pzs	
C	 Anillo Plano Ø8	11 pzs	
D	 Perno Ø6 x 80mm	4 pzs	
E	 Perno Ø6 x 40mm	3 pzs	
F	 Llave Tipo Allen	1 pz	
G	 Llave Maestra	1 pz	
H	 Tornillo para Madera	6 pzs	

Partes Claves			
No	Codigo	Descripción	Cant'd
1	647-BS831KDP40	Respaldo	1 pz
2	647-BS831KDP41	Asiento Completo	1 pz
3	647-BS831KDP42	Pierna Delantera	1 pz
4	647-BS831KDP43	Protector de Piso	1 pz
5	647-BS831KDP44	Viga Lateral Derecha	1 pz
6	647-BS831KDP45	Viga Lateral Izquierda	1 pz
7	647-BS831KDP49	Viga Frontal	1 pz
8	647-BS831KDP01F	Protector de Piso	4 pzs

#### PASO 1:

- Cuidadosamente coloque el respaldo en una superficie blanda como alfombra para evitar rasguños en el acabado.
- Coloque el Asiento al Resplado usando un Anillo Plano (C), un Anillo de Seguridad (B) y un Perno Corto (E) en cada uno de los hoyos pre-perforados en el marco. (Vea detalle A).
- Asegure las esquinas del Asiento al Resplado usando un Anillo Plano (C), un Anillo de Seguridad (B) y un Perno Largo (D) en cada uno de los hoyos pre-perforados en el marco. (Vea detalle B).
- Asegure todos los pernos con la Llave tipo Allen (F).

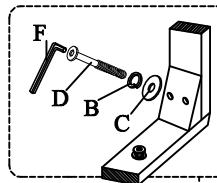

DETALLE B

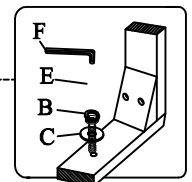
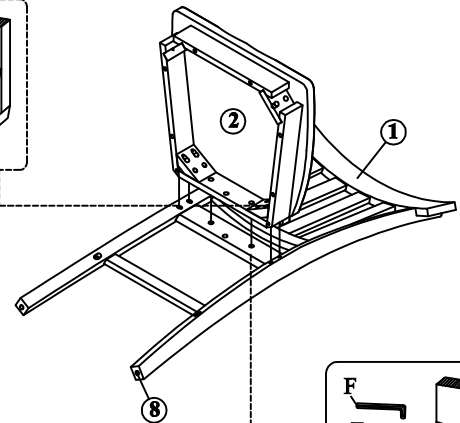

DETALLE A

#### DETALLE D

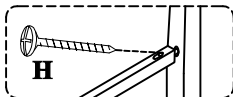

#### PASO 2:

- Cuidadosamente voltee el banco boca abajo en una superficie blanda como alfombra para asegurar las Piernas en cada esquina del marco del Asiento.
- Coloque las Piernas usando un Anillo Plano (C), un Anillo de Seguridad (B) y una Tuerca (A) en cada uno de los pernos de las Piernas, asegure usando la Llave Maestra (G).
- No asegure fuerte porque va a necesitar espacio para insertar las vigas (Vea Detalle C).
- Coloque las vigas laterales y la viga frontal, asegure usando el tornillo de madera usando un desarmador Phillips (no proporcionado). (Vea Detalle D).
- Asegure todos los pernos y tuercas fuerte sin dañar la pieza y antes de usar a silla.

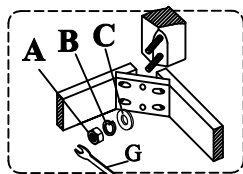
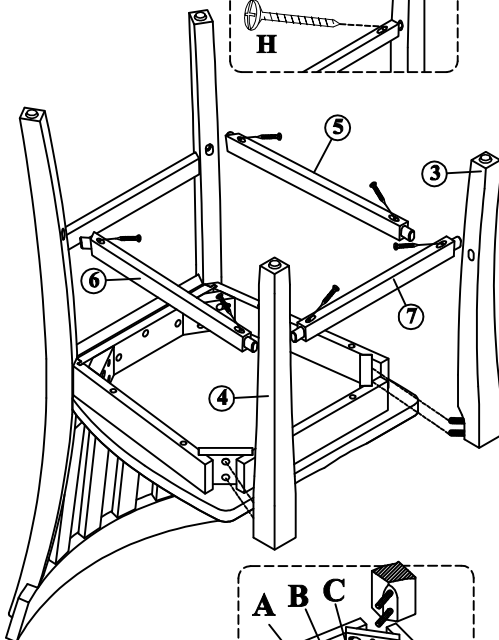

DETALLE C

