

Thank you for purchasing this quality product. Be sure to check all packing material carefully for small parts that may have come loose inside the carton during shipment

Parts Key			
No	Code	Qty	Description
1		1 pc	Table Top
2		1 pc	Storage Box
3		1 pc	Right Front Leg (with shelf holes)
4		1 pc	Left Front Leg (with shelf holes)
5		1 pc	Left Back Leg
6		1 pc	Right Back Leg
7		1 pc	Large Center Stretcher
8	647-60P11S	1 pc	Small Side Stretcher
9	647-60P01F	4 pcs	Floor Glide

Hardware kit 647-60P01			
No		Description	Q'Ty
A		Hexa Nut Ø8	8 pcs
B		Lock Washer Ø8.5	8 pcs
C		Flat Washer Ø8.5	8 pcs
D		Key Wrench	1 pc
E		Short Bolt Ø8 x 50mm	6 pcs
F		Allen Key	1 pc
G		Screw Ø4 x 40mm	4 pcs
H		Dowel Nut	6 pcs

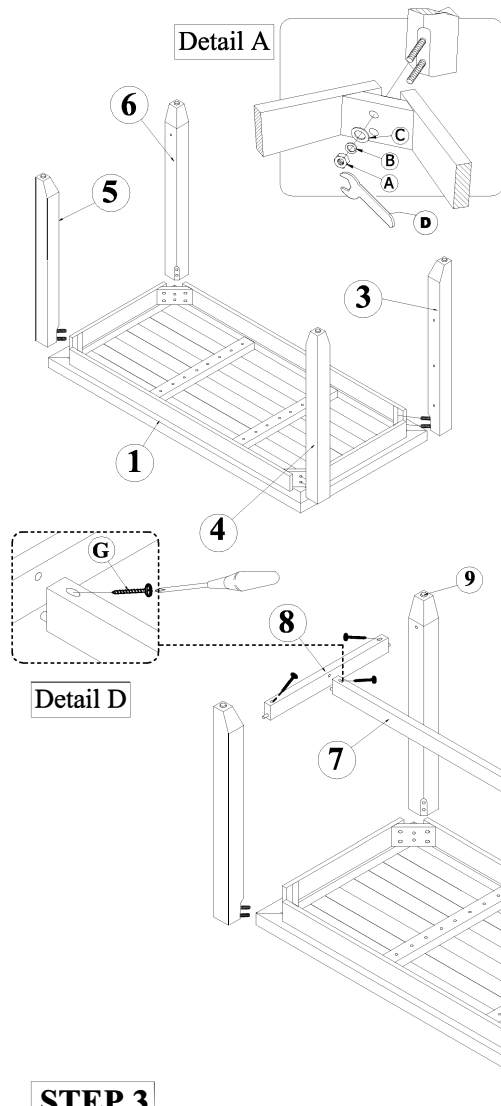

STEP 1

- Carefully lay Table top upside down on a smooth flat surface to prevent scratches.
- Attach each Leg to each corner of Table Top as shown in illustration. Insert a Flat Washer (C), Lock Washer (B) and Nut (A) on the bolts of each Leg. Do not fully tighten.

STEP 2

- Attach Storage box to Front Legs. Insert a Bolt (E) through holes in wood corner of Storage box. Fully tighten all bolts with Allen key (F). (See Detail B).
- Insert Dowel Nut(H) into holes of Storage box as shown illustration.(See Detail C)
- Fully tighten nuts in Front Legs by turning clockwise using provided Key Wrench until secure. (See Detail A)

STEP 3

- Insert Small Side Stretcher between Back Legs. Insert Large Center Stretcher between Storage box and Small Side Stretcher, fasten with Wood Screw using phillip-head screwdriver. (not provided). (See detail D).
- Fully tighten nuts in Back Legs using Key Wrench.
- Carefully turn Pub Table Storage upright.

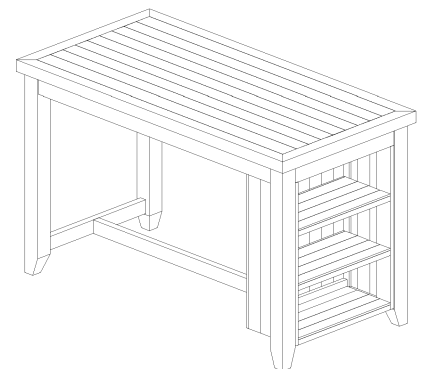

Merci d'avoir acheté ce produit de qualité. Soyez sûr de vérifier tout le matériel d'emballage avec soin pour petite part qui peut avoir été lâche à l'intérieur du carton pendant le transport.

Parts Key			
No	Code	Qty	Description
1	647-60P24	1 pc.	Dessus de Table
2	647-60P51	1 pc.	Cadre en bois
3	647-60P02R	1 pc.	Pied avant droite (avec étagères trous)
4	647-60P02L	1 pc.	Pied avant gauche (avec étagères trous)
5	647-60P02BL	1 pc.	Pied dos gauche
6	647-60P02BR	1 pc.	Pied dos droite
7	647-60P11C	1 pc.	Grand CentreTraverse
8	647-60P11S	1 pc.	Grand CôtéTraverse
9	647-60P01F	4 pcs.	Patin

Hardware kit 647-60P01			
No		Description	Q'Ty
A		Écrou Ø8	8 pcs
B		Rondelle Frein Ø8.5	8 pcs
C		Rondelle Plate Ø8.5	8 pcs
D		Clé Principale	1 pc
E		Boulon Ø8 x 50mm	6 pcs
F		Clé Hexagonale	1 pc
G		Vis Ø4 x 40mm	4 pcs
H		Cheville	6 pcs

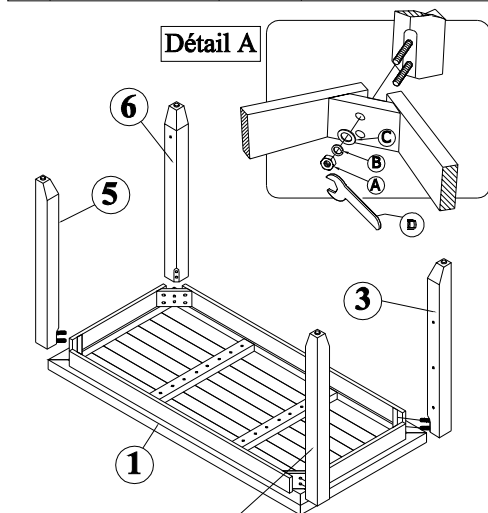

ÉTAPE 1

- Disposez soigneusement de table à l'envers sur une surface plane et lisse pour éviter les rayures.
- Attachez chaque Jambe à chaque coin de table comme indiqué dans l'illustration. Insérez une rondelle plate (C), Rondelle (B) et l'écrou (A) sur les boulons de chaque jambe. Ne serrez pas complètement.

ÉTAPE 2

- Fixez Boîte de rangement pour les pattes avant. Insérez un boulon (E) à travers des trous dans le coin de bois de la boîte de stockage. Serrer à fond tous les boulons avec une clé Allen (F). (Voir détail B).
- Insérez Goujon Ecrou (H) dans les trous de la boîte de stockage comme illustration ci (voir détail C)
- Entièrement Serrer les écrous dans les jambes avant en tournant dans le sens horaire à l'aide fournie Clef à molette jusqu'à sécurisé. (Voir détail A)

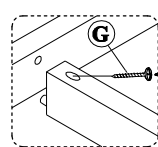

Détail D

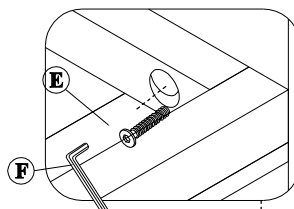

Détail B

ÉTAPE 3

- Insérer petit côté Brancard entre pattes arrière. Insérez Grand Centre Brancard entre la boîte et de stockage petit côté Brancard, fixer avec des vis à bois utilisant Phillip-tournevis. (non fourni). (Voir détail D).
- Serrer les écrous dans les pattes arrière à l'aide de la clé Clé.
- Tournez avec précaution Pub Storage Table verticale.

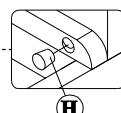

Détail C

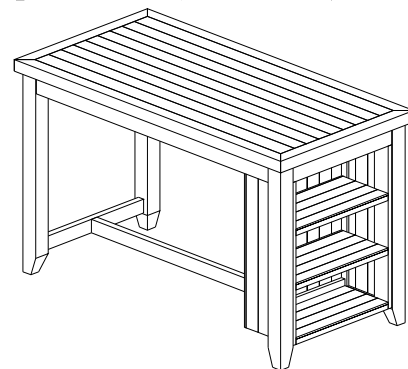

Gracias por comprar este producto de calidad. Por favor asegure que tenga todas las piezas en la caja, la partes pequeñas se pudieron haber movido de su lugar

Parts Key			
No	Code	Qty	Description
1	647-60P24	1 pz	Tabla
2	647-60P51	1 pz	Caja de Almacenamiento
3	647-60P02R	1 pz	Pierna Delantera Derecha (con agujeros de estante)
4	647-60P02L	1 pz	Pierna Delantera Izquierda (con agujeros de estante)
5	647-60P02BL	1 pz	Pierna Espalda Izquierda
6	647-60P02BR	1 pz	Pierna Espalda Derecha
7	647-60P11C	1 pz	Grande Centro Viga
8	647-60P11S	1 pz	Grande Lateral Viga
9	647-60P01F	4 pzs	Protector de Piso

Hardware kit 647-60P01			
No	Description	Q'Ty	
A	Tuerca Ø8	8 pzs	
B	Anillo de Seguridad Ø8.5	8 pzs	
C	Anillo Plano Ø8.5	8 pzs	
D	Llave Maestra	1 pz	
E	Perno Ø8 x 50mm	6 pzs	
F	Llave Tipo Allen	1 pz	
G	Tornillo para Madera	4 pzs	
H	Clavija de Madera	6 pzs	

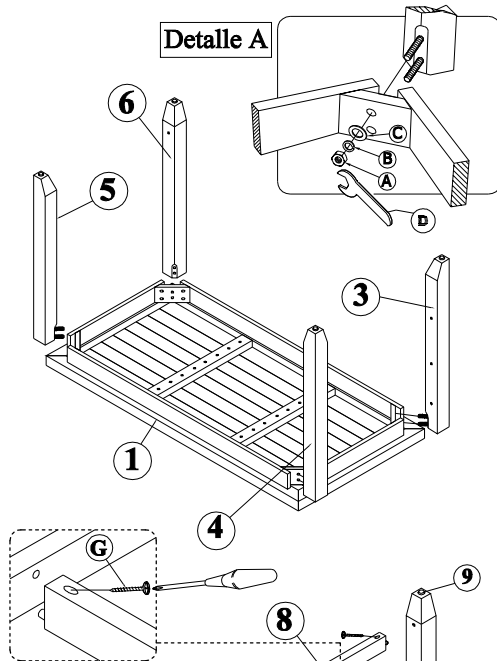

Detalle A

PASO 1

- Coloque con cuidado la tapa de tabla hacia abajo sobre una superficie lisa y plana para evitar arañazos.

- Fije cada pierna a cada esquina de la mesa como se muestra en la ilustración. Inserte una arandela plana (C), arandela de seguridad (B) y la tuerca (A) en los tornillos de cada pierna. No apriete completamente.

PASO 2

- Fijar la caja de almacenamiento de patas delanteras. Inserte un perno (E) a través de los agujeros en la esquina de madera de la caja de almacenamiento. Apriete completamente todos los tornillos con la llave Allen (F). (Ver detalle B).

- Inserte Pasador Tuerca (H) en los agujeros de la caja de almacenamiento como ilustración se muestra (Ver Detalle C)

- Totalmente Apriete las tuercas en las piernas delanteras, girando en sentido horario usando proporcionado llave hasta que quede firme. (Véase el detalle A)

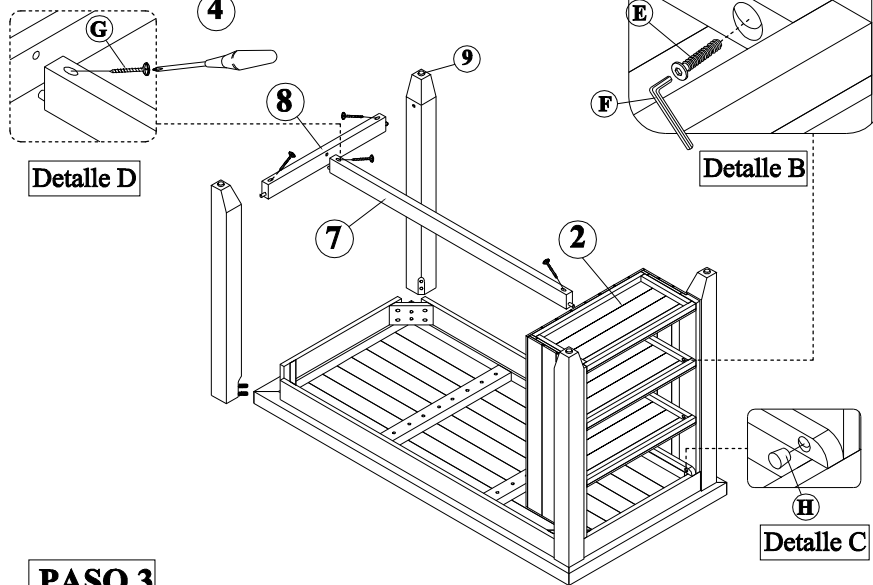

Detalle D

Detalle B

Detalle C

PASO 3

- Insertar Pequeño Side Camilla entre patas traseras. Inserte gran centro Camilla entre la caja y depósitos Pequeño Side Camilla, sujete con madera tornillo con un destornillador Phillip-cabeza. (no proporcionado). (Ver detalle D).

- Apretar las tuercas en Volver Piernas utilizando Llave de la llave.

- Gire cuidadosamente bar Tabla de almacenamiento vertical.

