

### 5-Pack Hardware Kit (592PO1)

#### Table Hardware

Ltr	Qty	Description
A	8 pcs	Flat Washer
B	8 pcs	Lock Washer
C	8 pcs	Nut Øm6
D	1 pc	Key Wrench

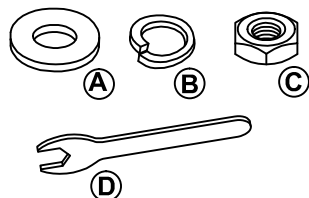

#### Table Parts Key

No	Code	Qty	Description
1	592P01FT	4 pcs.	TableFloor Glide
2	592P02	4 pcs.	Leg
3	592P24	1 pc.	Table top

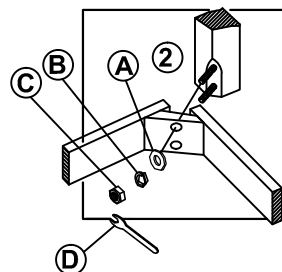

**Detail A**

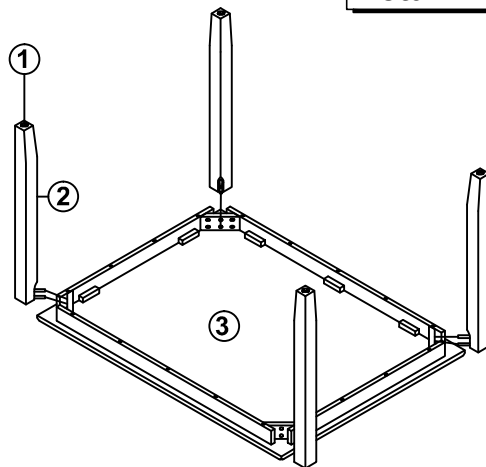

### STEP 1

- Carefully lay table top upside down on a smooth flat surface to prevent scratches.
- Affix a leg to each corner of the table top as shown in Detail A using a flat washer, lock washer and nut.
- Once all legs are in place, fully tighten the nuts

### 5-Pack Hardware Kit (592P46) Chair Hardware

Ltr	Qty	Description
A	44 pcs.	Flat Washer
B	44 pcs.	Lock Washer
C	16 pcs.	Nut Øm6
D	4 pcs.	Key Wrench
E	16 pcs.	Long KD. Bolt Øm6x 75mm.
F	12 pcs.	Short KD. Bolt Øm6x 40mm.
G	4 pcs.	Allen Wrench
H	24 pcs.	Screw Ø4 x 38mm

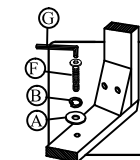
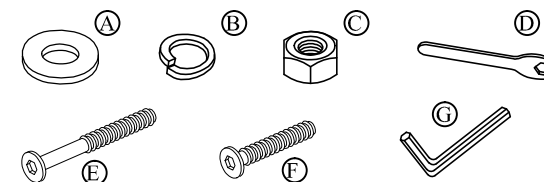

**Detail A**

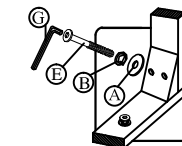

**Detail B**

### STEP 1

- Carefully lay chair back flat on a smooth flat surface to prevent scratches.
- Affix the complete seat to chair back, as shown in Detail A, using a flat washer, lock washer and short KD bolt.
- Secure complete seat to chair back corners, as shown in Detail B, using a flat washer, lock washer and long KD bolt. -- Tighten screws with provided Allen Wrench.

#### Chair Parts Key

No	Code	Qty	Description
5	592P01FC	16 pcs.	Chair Floor Glide
6	592P40	4 pcs.	Chair Back
7	592P41	4 pcs.	Complete Seat
8	592P42	4 pcs.	Right Facing Front Leg
9	592P43	4 pcs.	Left Facing Front Leg
10	592P44	4 pcs.	Right Facing Side Stretcher
11	592P45	4 pcs.	Left Facing Side Stretcher
12	592P49	4 pcs.	Front Stretcher

\* Quantities noted are for a total of four chairs.

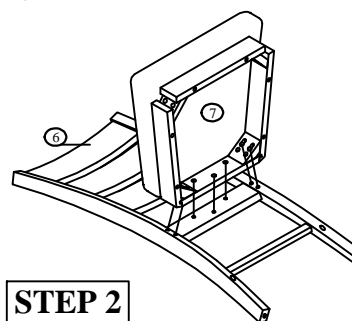

**Detail C**

### STEP 2

- Carefully turn Chair upside down and attach each Leg to the front corners of the Complete Seat. Noting Right and Left Side Leg.
- Place Flat Washer, Lock Washer and Nut on for each bolt, using provided Key Wrench.
- Do not fully tighten the Nuts at this stage until all the parts are in position (See Detail C).
- Insert 2 Side Stretchers between the Front Legs and Back Legs (Noting Right and Left Side Stretcher), and insert the Front Stretcher between the Front Legs; fasten with Wood Screw using phillip-head screwdriver. (not provided). (See Detail D)
- Be sure to tighten all screws and nuts prior to using Chair.

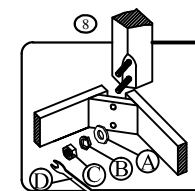

### DETAIL D

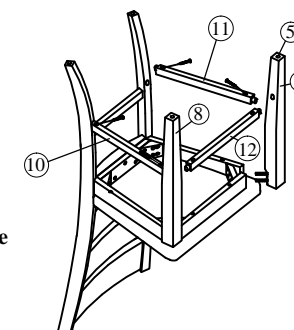

**FABRIC CARE INSTRUCTION**  
REGULAR CARE:  
Wipe gently using a soft damp cloth and mid detergent DO NOT SATURATE.  
FABRIC CONTENT:  
100% p/u vinyl; Cleaning code "W"