







# jOF FRAN INC.

## ASSEMBLY INSTRUCTIONS & PARTS IDENTIFICATION MODEL # 342-915KD X BACK CHAIR

Thank you for purchasing this quality product. Be sure to check all packing material carefully for small parts that may have come loose inside the carton during shipment

Parts Key			
No	Code	Qty	Description
1	342-915KDP40	1pc	Chair Back
2	342-915KDP41	1pc	Complete Seat
3	342-915KDP42	2pcs	Front Leg
4	342-915KDP01F	4pcs	Floor Glide

Hardware kit (342-915KDP46)			
No	Description		Qty
A		Hexa Nut ØM8	4 pcs.
B		Lock Washer ØM8	11 pcs.
C		Flat Washer ØM8	11 pcs.
D		Long KD.Screw ØM6mm x 75mm	4 pcs.
E		Short KD.Screw ØM6mm x 40mm	3 pcs.
F		Allen Key	1 pc.
G		Key Wrench	1 pc.

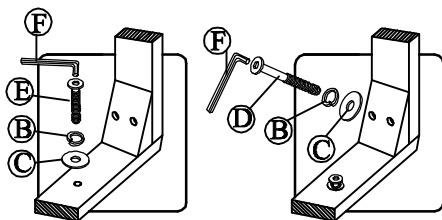

**DETAIL A**

**DETAIL B**

### STEP 1

- Carefully lay Chair Back flat on a smooth flat surface to prevent scratches.
- Affix Complete Seat to Chair Back by inserting a Flat Washer, Lock Washer and Short K.D. Screw into each of the hole on the back of the seat. Tighten screws with provided Allen Key by turning clockwise until secure. (See Detail A).
- Insert a Flat Washer, Lock Washer and Long K.D. Screw into each of 2 holes in the Complete Seat corners. Tighten screws with provided Key Wrench. (See Detail B).

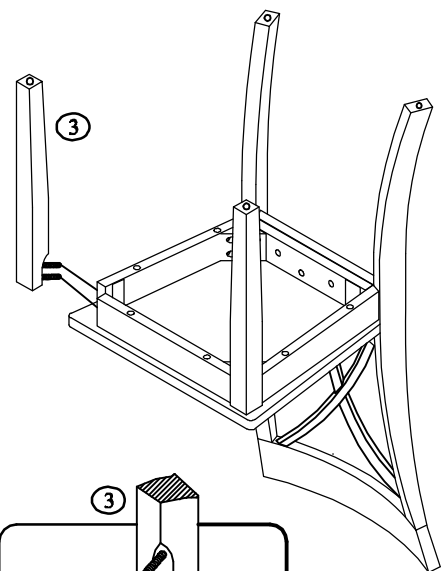
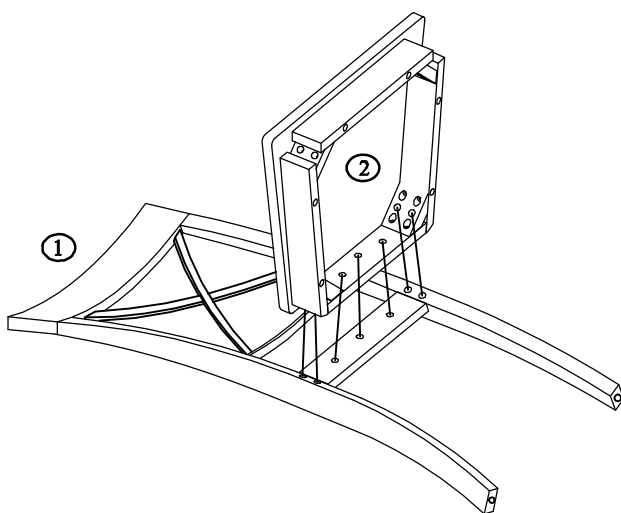

### STEP 2



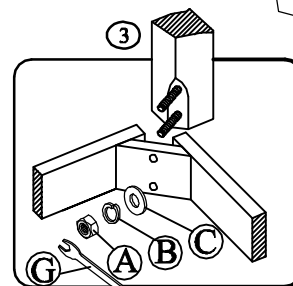



- Carefully turn chair upside down and affix each Leg to the front corners of the Complete Seat. Place Flat Washer, Lock Washer and Nut on each leg bolt, tightening the Nut on each Leg using provided Key Wrench. (See Detail C).
- Be sure to level the chair prior to tightening all the nuts/screws



**DETAIL C**

Merci d'avoir acheté ce produit de qualité. Soyez sûr de vérifier tout le matériel d'emballage avec soin pour petite part qui peut avoir été lâche à l'intérieur du carton pendant le transport.

Les pièces			
No	Code	Qty	Description
1	342-915KDP40	1pc	Dossier
2	342-915KDP41	1pc	Siège
3	342-915KDP42	2pcs	Pied
4	342-915KDP01F	4pcs	Patin

Trousse de quincaillerie (342-915KDP46)			
No	Description		Qty
A		Écrou ØM8	4 pcs.
B		Rondelle Plate ØM8	11 pcs.
C		Grand Rondelle Plate ØM8	11 pcs.
D		K.D. Vis ØM6mm x 75mm	4 pcs.
E		K.D. Vis ØM6mm x 40mm	3 pcs.
F		Clé Hexagonale	1 pc.
G		Clé Principale	1 pc.

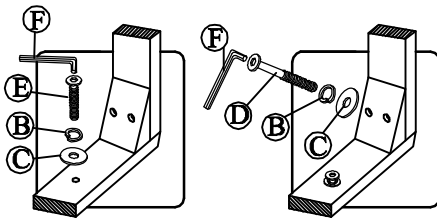

DÉTAIL A

DÉTAIL B

### ÉTAPE 1

- Placez avec soin le dossier sur une surface plane et lisse pour éviter les rayures
- Attachez le siège au dossier avec une rondelle plate, une rondelle et une vis courte KD pour chaque trou sur le dos de la chaise. Serrez les vis avec la clé allen fournie. (Détail A).
- Insérez une rondelle plate, une rondelle frein et une vis longue KD dans chacun des trous dans les coins du siège. Serrez les vis avec la clé allen fournie (Détail B)

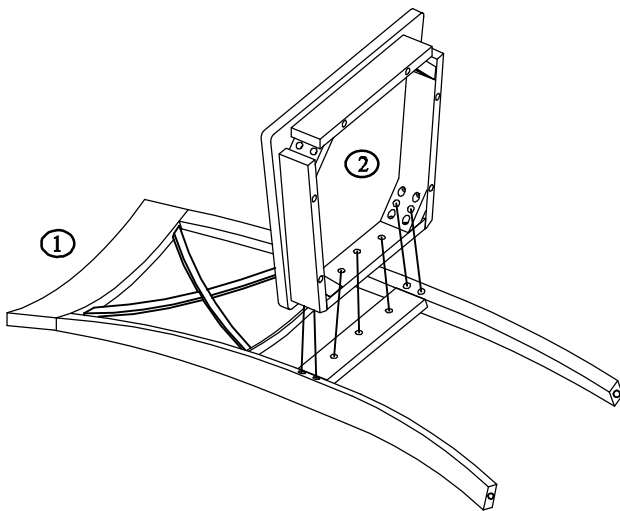

### ÉTAPE 2



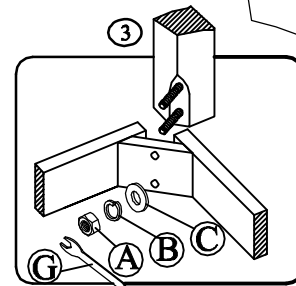
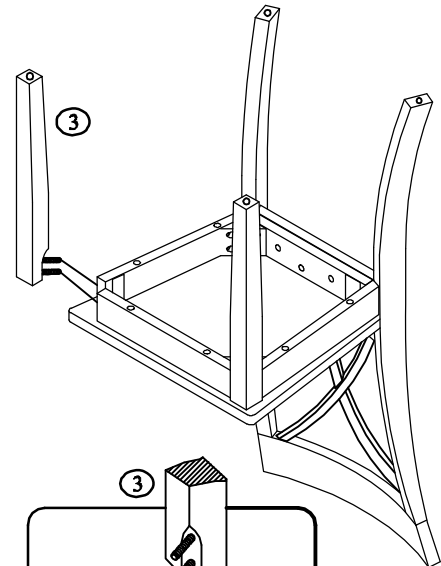



- Tournez soigneusement chaise à l'envers et attachez chaque pied aux coins avant siège. Placez une rondelle plate, une rondelle frein et un écrou sur chaque boulon, resserrez les écrous avec clé fournie. (Détail C).
- Resserrez bien toutes les vis et écrous avant d'utiliser la chaise.



D'TAIL C

Gracias por comprar este producto de calidad. Por favor asegure que tenga todas la piezas en la caja, la partes pequeñas se pudieron haber movido de su lugar

Lista de partes			
No	Clave	Cant	Descripción
1	342-915KDP40	1pz	Respaldo Completo
2	342-915KDP41	1pz	Asiento Completo
3	342-915KDP42	2pzs	Piernas Delanteras
4	342-915KDP01F	4pzs	Protector de Piso

Trousse de quincaillerie (342-915KDP46)		
L.t	Descripción	Qty
A	 Tuerca ØM8	4 pzs.
B	 Anillo de Seguridad ØM8	11 pzs.
C	 Anillo Plano ØM8	11 pzs.
D	 Perno tipo KD largo ØM6mm x 75mm	4 pzs.
E	 Perno tipo KD Cort oØM6mm x 40mm	3 pzs.
F	 Llave tipo Allen	1 pz.
G	 Llave maestra	1 pz.

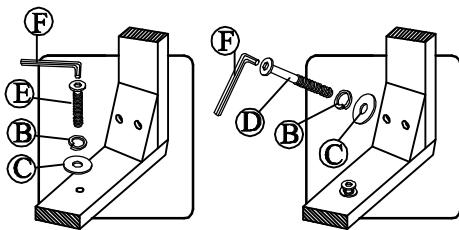

**Detalle A**

**Detalle B**

### PASO 1

- Cuidadosamente coloque el Respaldo de la silla boca arriba en superficie blanda para evitar rasguños en el acabado.
- Coloque el Asiento a el Respaldo usando un Anillo Plano (C), un Anillo de Seguridad (B) y un Perno tipo K.D. Corto (E), como se demuestra en el dibujo. Atornille en los dos orificios en el marco del Asiento. Asegure los pernos con la Llave tipo Allen (F) proporcionada. (Vea Detalle A).
- Asegure las esquinas usando un Anillo Plano (C), un Anillo de Seguridad (B) y un Perno tipo K.D. Largo (D), como se demuestra en el dibujo. Atornille en cada uno de los dos orificios en las esquinas del Asiento. Asegure los pernos con la Llave tipo Allen (F) proporcionada. (Vea Detalle B)

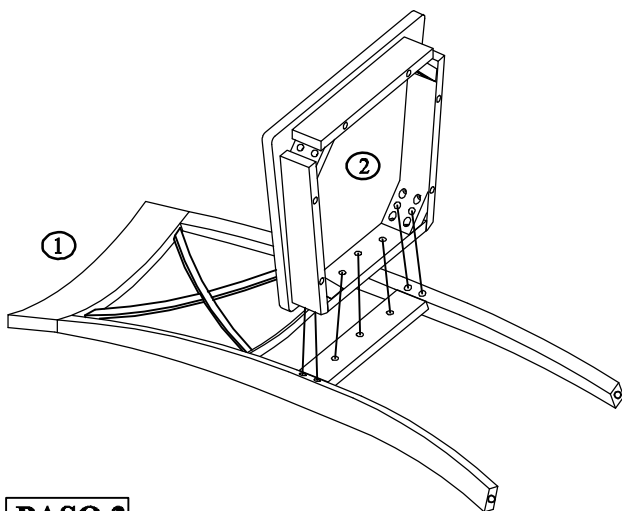

### PASO 2

- Cuidadosamente voltee la silla ensamblada boca abajo. Coloque las Piernas Delanteras en cada esquina del Asiento, como se demuestra en el dibujo, usando un Anillo Plano (C), un Anillo de Seguridad (B) y una Tuerca (A). Atornille en cada uno de los dos orificios en el marco del Asiento . Asegure los pernos con la Llave Maestra (G) proporcionada. (Vea Detalle C)
- Por favor asegure que los tuercas estén fijos y bien atornillados antes de usar la silla. Atornille fuertemente sin dañar la pieza.

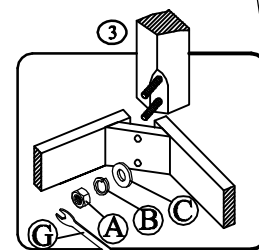
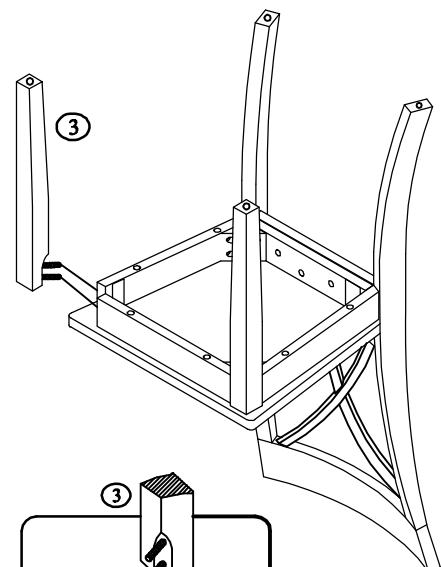

**Detalle C**