



furnishing better
lives together

WWW.JOFRAN.COM

ASSEMBLY INSTRUCTION & PARTS IDENTIFICATION MODEL # 2351-79B/79T SEQUOIA DINING TABLE

Thank you for purchasing this quality product. Be sure to check all packing material carefully for small parts that may have come loose inside the carton during shipment.

TABLE COMPONENTS			
No		Qty	Description
1		1 Pcs	Sequoia Dining Table Top
2		2 Pcs	Sequoia Base Pedestal
3		8 Pcs	Felt Pad
4	2351-79BP02B	2 Pcs	Metal Attachment Plate

TABLE HARDWARE KIT 2351-79TP01			
No.		Description	Qty
A		CSK Allen Bolt M8 x 25mm	6 Pcs
B		JCB Allen Bolt M8 x 25mm	8 Pcs
C		Flat Washer	8 Pcs
D		Allen Key	1 Pcs

NOTE:

Two people are required to set up this table
Two base cartons required for the table
Do not transport the table with the pedestals attached.

STEP 1

Loosen the center bolt holding the attachment plate in place. Rotate the attachment plate to fit into the notched groove.

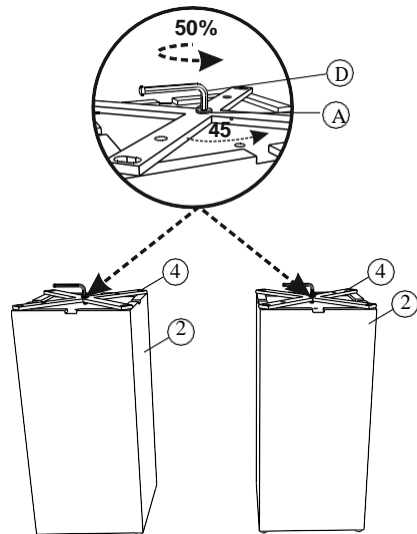

STEP 2

Secure the metal attachment plate to the base using the Bolt A and hand tightening all bolt with the provided Allen Key.

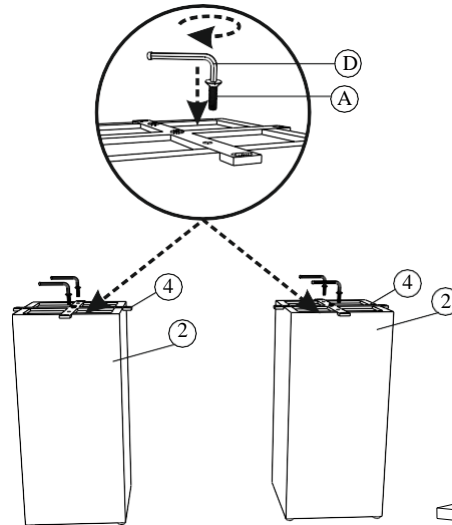

STEP 3

Attach the two bases to the tabletop using a Bolt and Flat Washer. Once all bolts are in place, fully tighten all bolts with provided Allen Key.

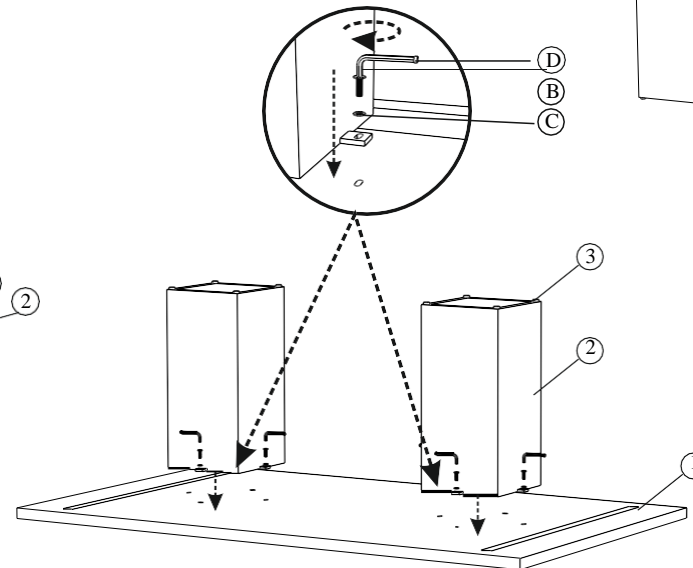

STEP 4

With the second person, carefully turn the table right side up.

