

ASSEMBLY INSTRUCTIONS & PARTS IDENTIFICATION MODEL # 2300-7 RECLAMATION CHAIRSIDE TABLE

Thank you for purchasing this quality product. Be sure to check all packing material carefully for small parts that may have come loose inside the carton during shipment.

Parts			
No.	Code	QTY	Description
1		1 PC	Table Top
2	2300-7P08	1 PC	Shelf
3	2300-7P02	4 PCS	Leg
4	2300P01F	4 PCS	Floor Glides

Hardware Kit - 2300-7P01			
No		Description	QTY
A		FLAT WASHER M8X18	12 PCS
B		LOCK WASHER	12 PCS
C		BOLT M8X45	12 PCS
D		WRENCH	1 PC

ASSEMBLY MAY REQUIRE TWO PEOPLE

STEP 1

LAY THE TABLETOP UPSIDE DOWN ON A SMOOTH SURFACE TO PREVENT SCRATCHING.

ATTACH THE LEGS AS SHOWN USING A BOLT, LOCK WASHER AND FLAT WASHER. DO NOT FULLY TIGHTEN AT THIS POINT.

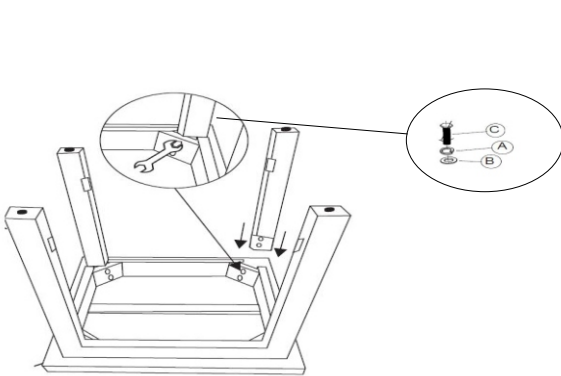

STEP 2

PLACE THE SHELF INTO POSITION AS SHOWN AND ATTACH WITH A BOLT, LOCK WASHER AND FLAT WASHER. HAND TIGHTEN WITH THE WRENCH PROVIDED.

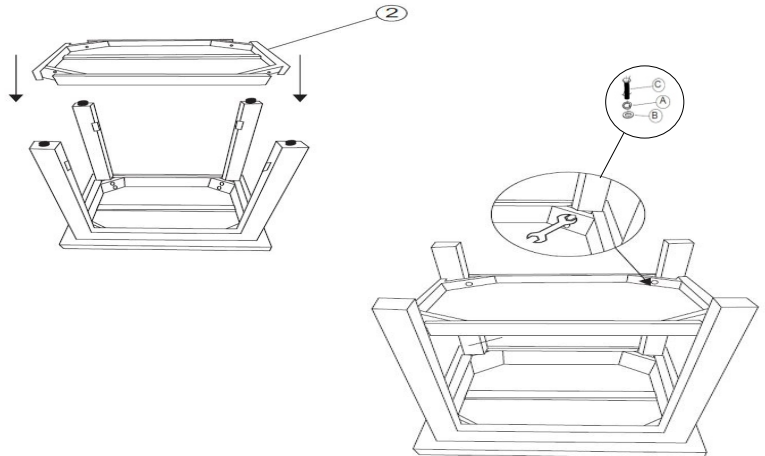

STEP 3

FULLY TIGHTEN THE LEGS TO THE TABLE TOP USING THE WRENCH PROVIDED

