

ASSEMBLY INSTRUCTIONS & PARTS IDENTIFICATION

2271-OWENSTJD

JADE

JOFRAN INC.

Hardware kit (2271-OWENSTP46)

Ltr	Qty	Description
A	9PCS.	BOLT ØM6X16MM
B	4PCS.	BOLT ØM6X28MM
C	4PCS.	FLAT WASHER
D	1PC	ALLEN WRENCH
E	4PCS.	BOLT ØM6X20MM

Parts Key

No	Code	Qty	Description
1	2271-OWENSTP42B	1PC	LEG ASSEMBLY
2	2271-OWENSTP40	1PC	BACK FRAME
3	2271-OWENSTP49	1PC	FOOTREST
4	2271-OWENSTJDP40C	1PC	BACK CUSHION
5	2271-OWENSTJDP41C	1PC	SEAT CUSHION
6	2271-OWENP01L	4PC	LEVELER

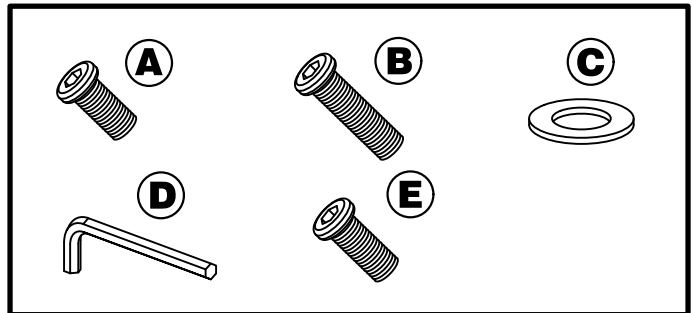

STEP 1:

- . Attach the leg assembly to the seat by inserting a flat washer and short bolt A per the diagram.
- . Attach the backrest frame to the seat by inserting short bolt A per the diagram.
- . Attach the footrest to the leg by inserting medium bolt E per the diagram.
- . Do not fully tighten at this point.

STEP 1:

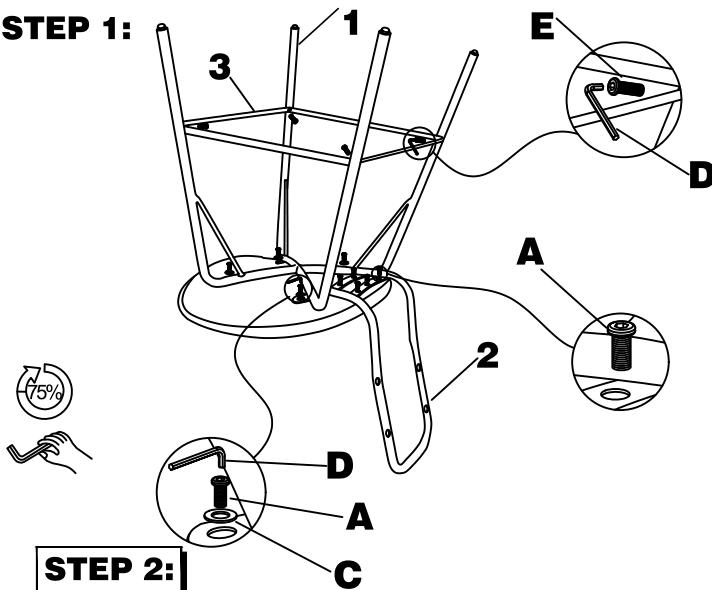

STEP 2:

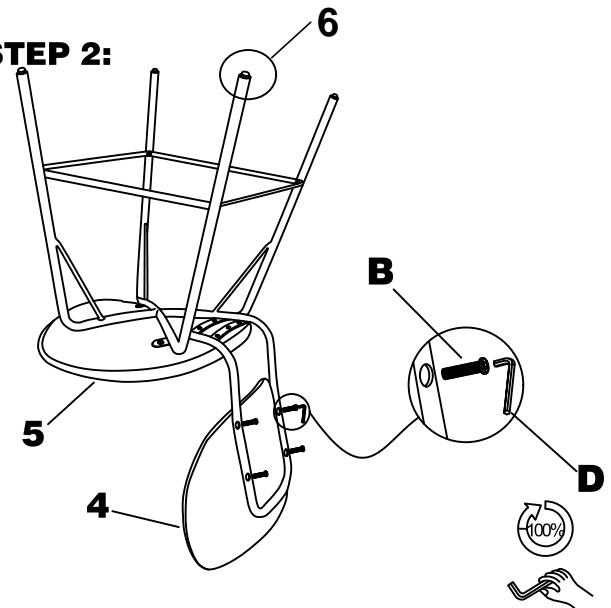

STEP 2:

- . Attach the backrest to the backrest frame by inserting long bolt B per the diagram.
- . Do not fully tighten the bolts until all are in place.
- . Once all bolts are in place, fully tighten the bolts by hand using the provided Allen Wrench. DO NOT use a power tool to tighten.
- . Use the floor levelers to level the chair, if needed.

*** FABRIC CARE:

Avoid direct sunlight, water, oil, acid, sharp objects etc.
 Use vacuum cleaner to clean. Wipe spills immediately.
 If needed, spot clean with a mild water-based soap.
 Fabric content 100% Polyurethane, Cleaning Code W

