

2271-MADDOXST

Hardware kit (2271-MADDOXSTP46)

Ltr	Qty	Description
A	8PCS.	BOLT ØM6X20MM
B	4PCS.	BOLT ØM6X45MM
C	4PCS.	FLAT WASHER
D	1PC	ALLEN WRENCH
E	1PC	SUPPORT BRACKET

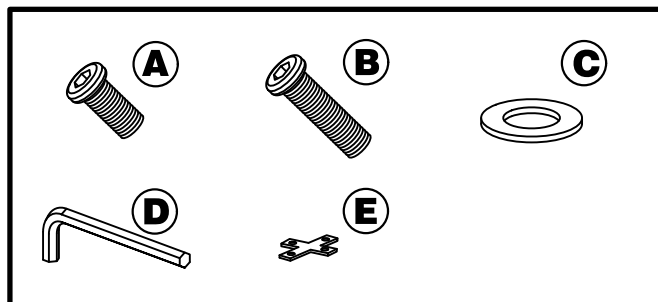

STEP 1:

- . Carefully place the upper leg and the lower leg assemblies together upside down to prevent scratches on the legs as shown in Step 1.
- . Connect the legs with the support bracket E and bolts A. Do not fully tighten at this point
- . Install footrest using bolt A.

Parts Key

No	Code	Qty	Description
1	2271-MADDOXSTP43	1PC	UPPER LEG ASSEMBLY
2	2271-MADDOXSTP42	1PC	LOWER LEG ASSEMBLY
3	2271-MADDOXSTP49	1PC	FOOTREST
4	2271-MADDOXP01L	4PCS.	FLOOR LEVELER

STEP 1:

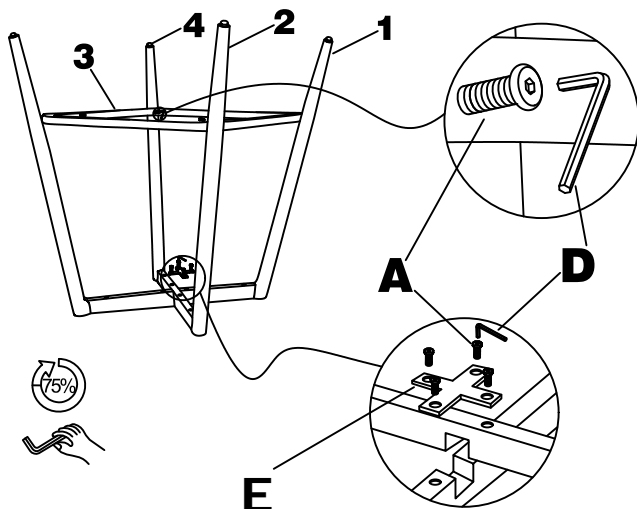

STEP 2:

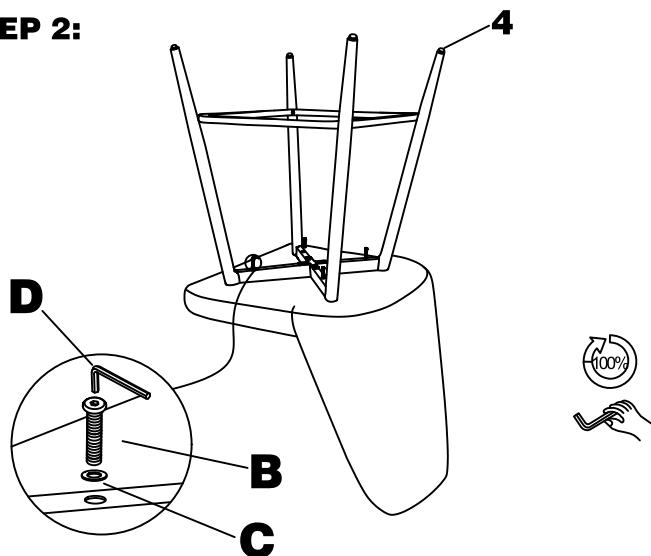

STEP 2:

- . Attach the assembled legs to the seat by inserting a flat washer and bolt B per the diagram.
- . Do not fully tighten the bolts until all bolts are in place.
- . Once all bolts are in place, fully tighten the bolts by hand using the provided Allen Wrench. Do not use a power tool to tighten.
- . Use the floor levelers to level the chair, if needed.

*** FABRIC CARE:

Avoid direct sunlight ,water,oil,acid,sharp objects etc. Use a vacuum cleaner to clean. Wipe spills immediately. If needed, spot clean with a mild water-based soap. Wipe dry with a clean cloth
Fabric content 100% Polyurethane, Cleaning code W

