

ASSEMBLY INSTRUCTIONS & PARTS IDENTIFICATION

2271-OWENCHGRY

GREY

JOF FRAN INC.

Hardware kit (2271-OWENCHP46)

Ltr	Qty	Description
A	9PCS.	BOLT ØM6X16MM
B	4PCS.	BOLT ØM6X28MM
C	4PCS.	FLAT WASHER
D	1PC	ALLEN WRENCH

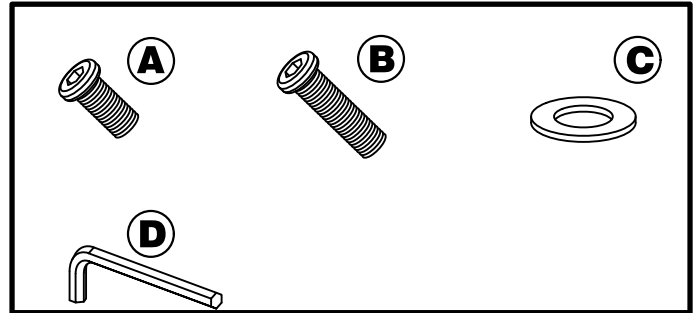

STEP 1:

- . Attach the leg assembly to the seat by inserting a flat washer and short bolt A per the diagram.
- . Attach the back rest frame to the seat by inserting short bolt A per the diagram.
- . Do not fully tighten at this point.

Parts Key

No	Code	Qty	Description
1	2271-OWENCHP42B	1PC	LEG ASSEMBLY
2	2271-OWENCHP40	1PC	BACK FRAME
3	2271-OWENCHGRYP40C	1PC	BACK CUSHION
4	2271-OWENCHGRYP41C	1PC	SEAT CUSHION
5	2271-OWENP01L	4PCS	LEVELER

STEP 2:

STEP 1:

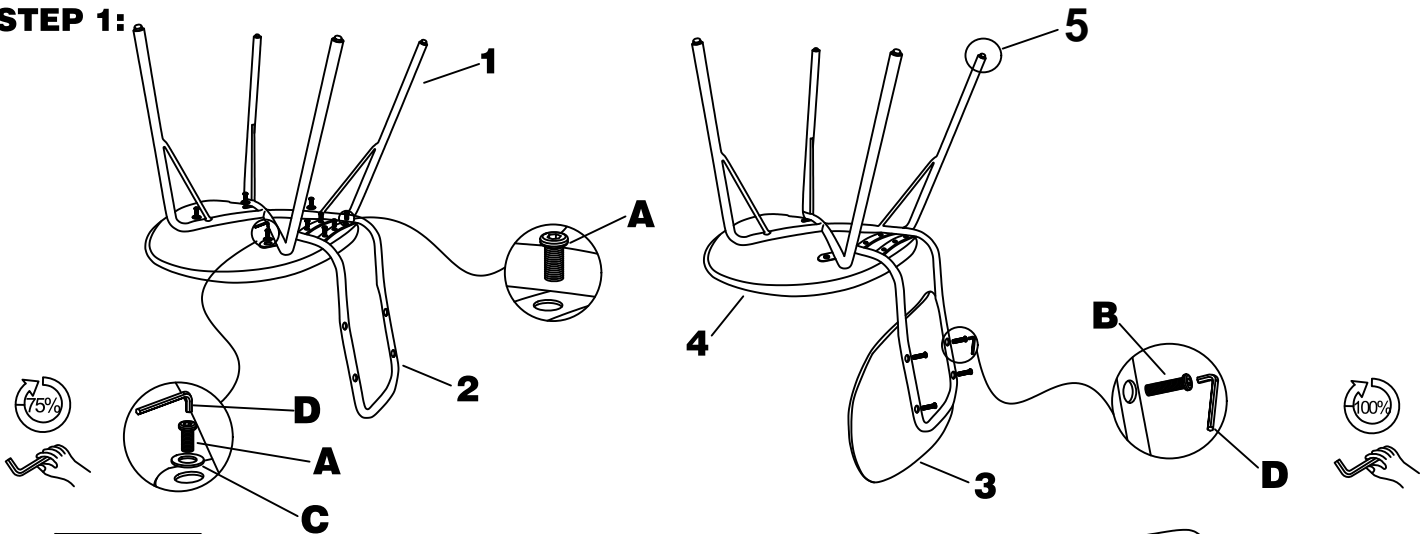

STEP 2:

- . Attach the backrest cushion to the backrest frame by inserting longer bolt B per the diagram.
- . Do not fully tighten the bolts until all are in place.
- . Once all bolts are in place, fully tighten the bolts by hand using the provided Allen Wrench. DO NOT use a power tool to tighten.
- . Use the floor levelers to level the chair, if needed.



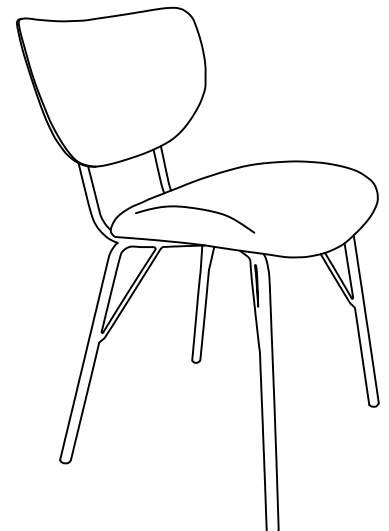

*** FABRIC CARE:

Avoid direct sunlight, water, oil, acid, sharp objects etc.
 Use vacuum cleaner to clean. Wipe spills immediately.
 If needed, spot clean with a mild water-based soap.
 Fabric content 100% Polyurethane, Cleaning Code W



Thank you for purchasing this quality product. Be sure to check all packing material carefully for small parts that may have come loose inside the carton during shipment

Key Parts			
No	Code	QTY	Description
1		1 pc	Table Top
2	2271-COLBYDLNP02	4 pcs	Table Leg
3	2271-COLBYP01F	4 pcs	Floor Glide
4	2271-COLBYDLNP01H	6 pcs	Hindge with Screw
5	2271-COLBYDLNP28	2 pcs	Drop Leaf
6	2271-COLBYDLNP36	4 pcs	Drop Left Support
7	2271-COLBYDLNP36W	4pcs	Leaf Support Wedge

Hardware kit 2271-COLBYDLNP01			
No		Description	Qty
A		Flat washer Ø5/16"	8 pcs
B		Lock washer Ø5/16"	8 pcs
C		Nut Ø5/16"	8 pcs
D		Key wrench	1 pc

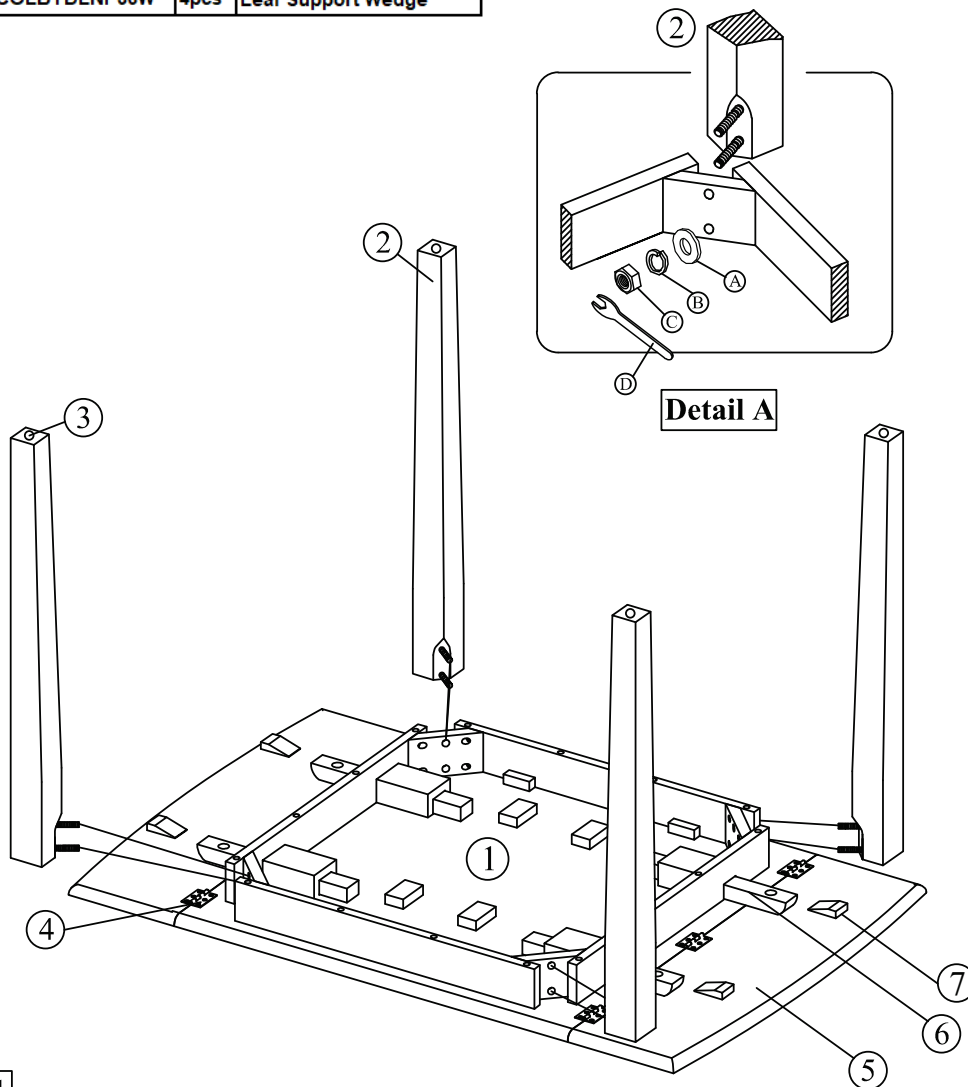

STEP 1

- Carefully lay Table Top upside down on a smooth flat surface to prevent scratches.
- Affix each Leg to each corner of the Table Top as shown in illustration. Insert a Flat Washer, Lock Washer and Nut on to the bolts of each Leg
- Once all Legs are in place, fully tighten nuts by turning clockwise using provided Key Wrench until secure. (See Detail A)

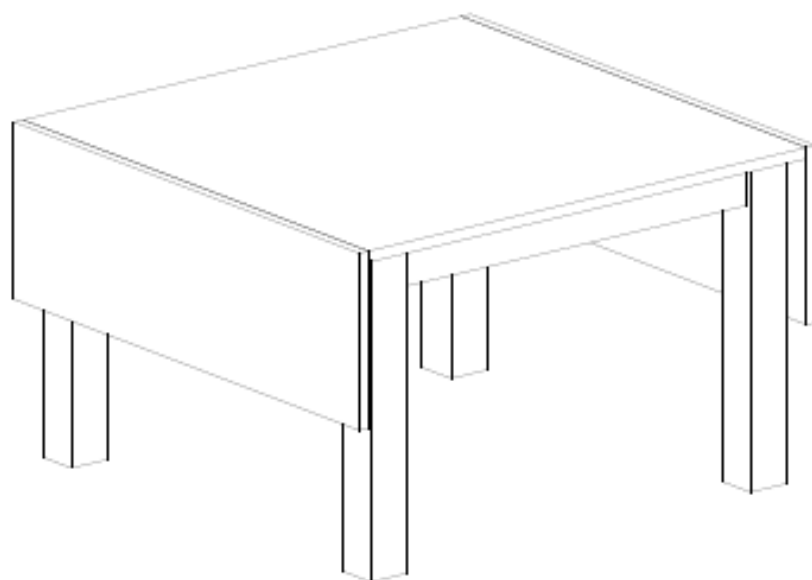

Step 2

Lift the Leafs on the side of Table Top and slide out the Cleats below to set the leaves.
Slide in the Cleats to Drop the Leafs.

