

### 2271-MADDOXCH

#### Hardware kit (2271-MADDOXCHP46)

Ltr	Qty	Description
A	4PCS.	BOLT ØM6X16MM
B	4PCS.	BOLT ØM6X45MM
C	4PCS.	FLAT WASHER
D	1PC	ALLEN WRENCH
E	1PC	SUPPORT BRACKET

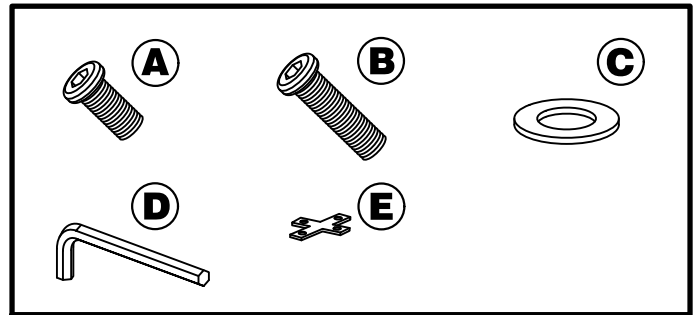

#### STEP 1:

Carefully place the upper leg and the lower leg assemblies together upside down to prevent scratches on the legs as shown in Step 1.

Connect the legs with the support bracket E and bolts A. Do not fully tighten at this point

#### Parts Key

No	Code	Qty	Description
1	2271-MADDOXCHP43	1PC	UPPER LEG ASSEMBLY
2	2271-MADDOXCHP42	1PC	LOWER LEG ASSEMBLY
3	2271-MADDOXP01L	4PCS.	FLOOR LEVELER

#### STEP 1:

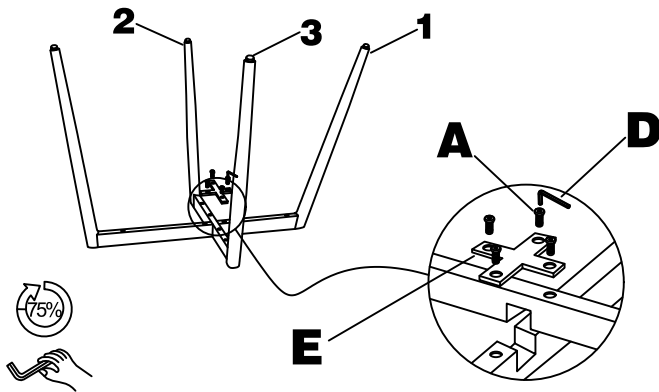

#### STEP 2:

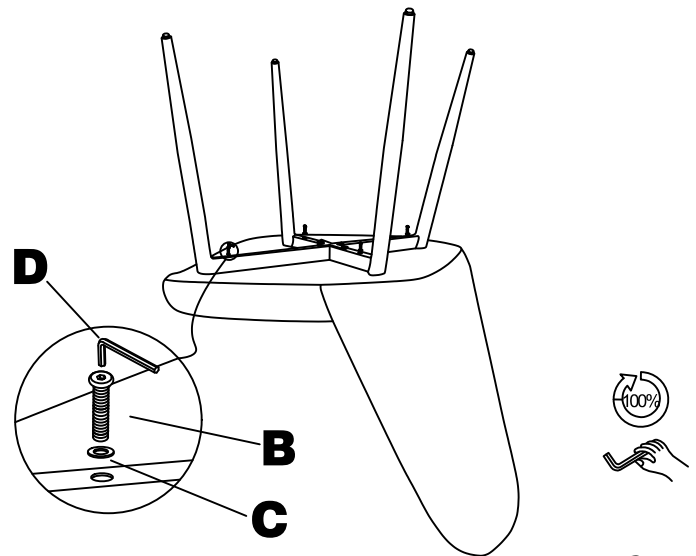

#### STEP 2:

- . Attach the assembled legs to the seat by inserting a flat washer and bolt B per the diagram.
- . Do not fully tighten the bolts until all are in place.
- . Once all bolts are in place, fully tighten the bolts by hand using the provided Allen Wrench. Do not use a power tool to tighten.
- . Use the floor levelers to level the chair, if needed.

#### \*\*\* FABRIC CARE:



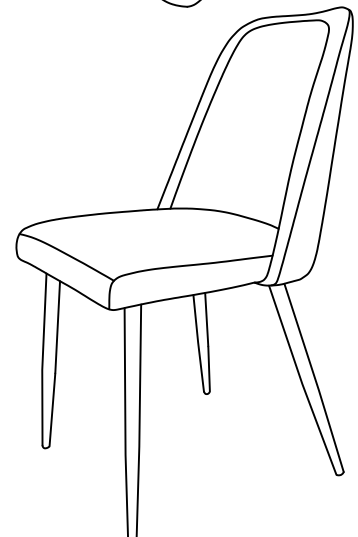



Avoid direct sunlight, water, oil, acid, sharp objects etc. Use a vacuum cleaner to clean. Wipe spills immediately. If needed, spot clean with a mild water-based soap. Wipe dry with a clean cloth  
Fabric content 100% Polyurethane, Cleaning code W



## ASSEMBLY INSTRUCTIONS & PARTS IDENTIFICATION MODEL # 2271-BURKEDTG BURKE RECT TABLE - GOLDEN

Thank you for purchasing this quality product. Be sure to check all packing material carefully for small parts that may have come loose inside the carton during shipment

KeyParts			
No	Code	Qty	Description
1	2271-BURKEDTGP24	1pc	Tabletop
2	2271-BURKEDTGP53	2pcs	Leg Assembly
3	2271-BURKEDTGP11	1pcs	Support Stretcher
4	2271-BURKEP01F	4pcs	Floor Glide

Hardware kit (2271-BURKEDTGP01)			
No	Description		Qty
A		Flat washer (Large) For Bracket	16 pcs
B		Flat washer (Small) For Stretcher	3 pcs
C		Lockwasher	19 pcs
D		Bolt 8x25mm - To attach the Bracket	16 pcs
E		Bolt 8x75mm - To attach Support Stretcher	3 pcs
F		Allen Key	1 pcs
G		Metal Corner Bracket	8 pcs

### Step 1

Attach the Support Stretcher to the tabletop using a Long Bolt E, Lock Washer C, and Small Flat Washer B. Fully tighten all bolts after all three bolts are in place.

SETUP REQUIRES 2 PEOPLE

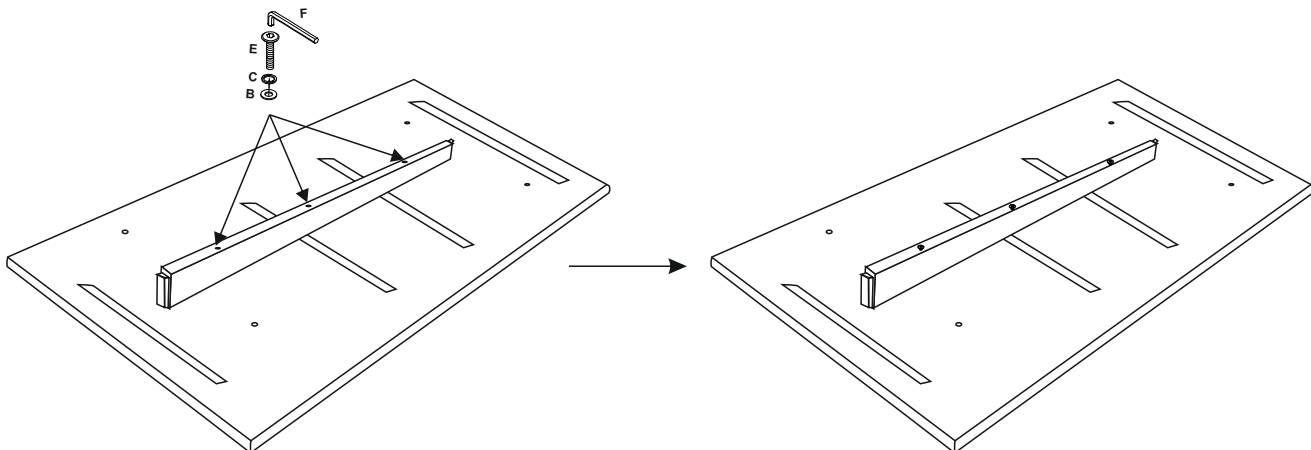

### Step 2

Attach two Metal Corner Brackets G to the inside and outside of each panel of the Leg Assembly using a Short Bolt D, Lock Washer C, and Large Flat washer A. Do not fully tighten at this point.

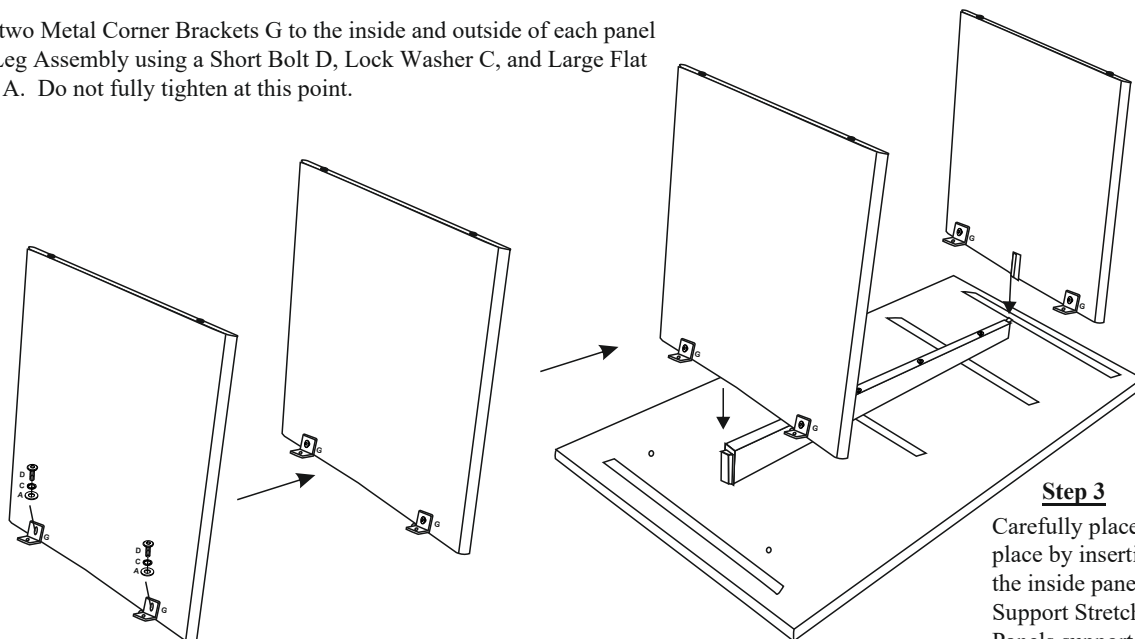

### Step 3

Carefully place the Leg Assembly into place by inserting the notched portion of the inside panel to the receiver on the Support Stretcher. Keep Leg Assembly Panels supported.

## ASSEMBLY INSTRUCTIONS & PARTS IDENTIFICATION MODEL # 2271-BURKEDTG BURKE RECT TABLE - GOLDEN

Thank you for purchasing this quality product. Be sure to check all packing material carefully for small parts that may have come loose inside the carton during shipment

KeyParts			
No	Code	Qty	Description
1	2271-BURKEDTGP24	1pc	Tabletop
2	2271BURKEDTGP53	2pcs	Leg Assembly
3	2271-BURKEDTGP11	1pcs	Support Stretcher
4	2271-BURKEP01F	4pcs	Floor Glide

Hardware kit (2271-BURKEDTGP01)			
No	Description		Qty
A		Flat washer (Large) For Bracket	16 pcs
B		Flat washer (Small) For Stretcher	3 pcs
C		Lockwasher	19 pcs
D		Bolt 8x25mm - To attach the Bracket	16 pcs
E		Bolt 8x75mm - To attach Support Stretcher	3 pcs
F		Allen Key	1 pcs
G		Metal Corner Bracket	8 pcs

### Step 4

Attach the Metal Corner Bracket to the tabletop using a Short Bolt D, Lock Washer C, and Large Flat washer A. Once all bolts are on place, fully tighten by hand using the provided Allen Key.

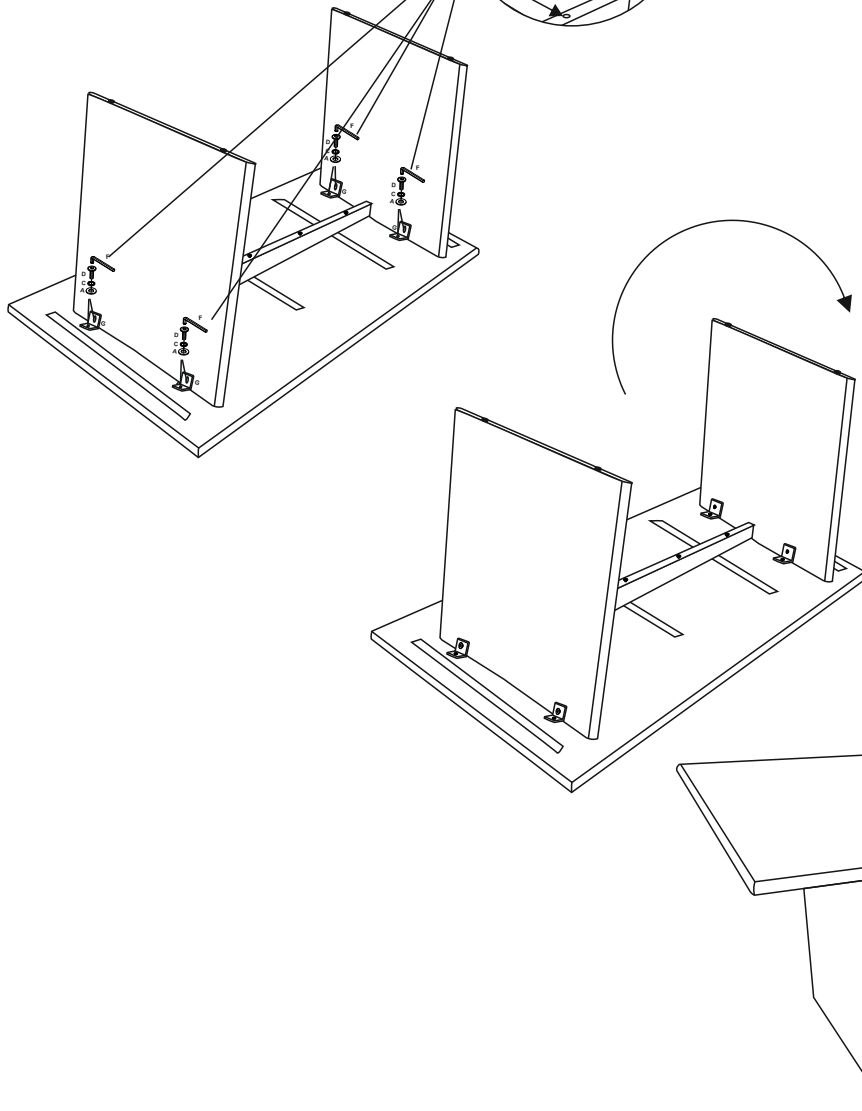
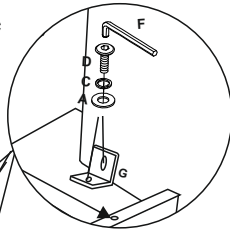

**SETUP REQUIRES 2 PEOPLE**



### Step 5

With the help of a second person turn the table upright. Do not put any pressure on the end flat portion of the leg panel when turning the table.