

**ISABELLA 86KD" FIVE DOORS ACCENT CABINET  
2250-86KD / 2251-86KD / 2252-86KD / 2253-86KD**

**QR CODE TO ACCESS INSTRUCTIONAL SETUP VIDEO**

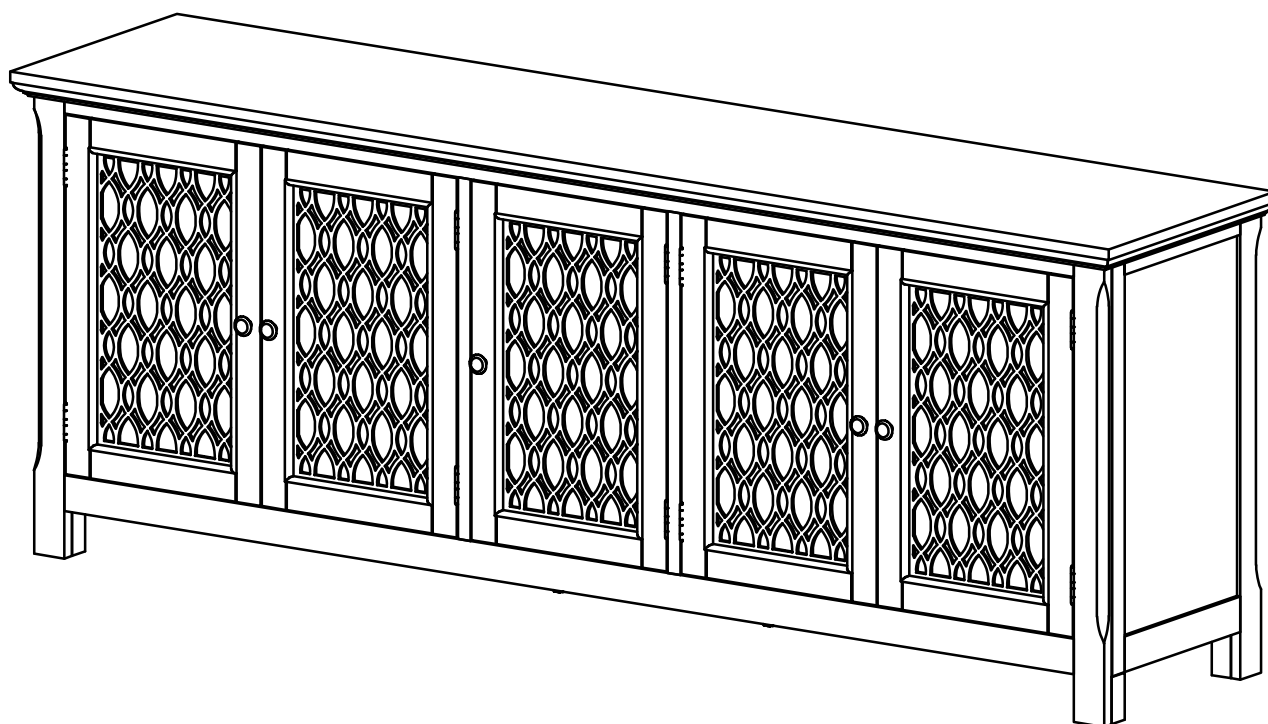

### Parts key

No	Code	Qty	Description	No	Code	Qty	Description
1	2250-86KDP54	1 pc	Top	11	2250-86KDP07L	2 pcs	Left Side Facing End Door
2	2250-86KDP51B	1 pc	Bottom Shelf	12	2250-86KDP07R	2 pcs	Right Side Facing End Door
3	2250-86KDP53	1 pc	Front Frame	13	2250-86KDP07M	1 pc	Middle Door
4	2250-86KDP51L	1 pc	Left Side Facing Side Panel	14	2250P51H	4 pcs	Side Panel Hinge
5	2250-86KDP51R	1 pc	Right Side Facing Side Panel	15	2250P07H	10 pcs	Door Hinge
6A	2250-86KDP08VL	1 pc	Vertical Partition Left	16	2250P02M	2 pcs	Middle Leg
6B	2250-86KDP08VR	1 pc	Vertical Partition Right	17	2250P01L	6 pcs	Leveler
7	2250-86KDP08S	2 pcs	Side Shelf	18	2250P01D	3 pcs	Door Catch
8	2250-86KDP08M	1 pc	Middle Shelf	19	2250P01AT	1 set	Anti-Tip Kit
9	2250-86KDP38S	2 pcs	Side Back Panel				
10	2250-86KDP38M	1 pc	Middle Back Panel				
Hardware Kit 2250-86KDP01							
No	Code	Qty	Description	No	Code	Qty	Description
20	2250P08P	12 pcs	Shelf Pin	22	2250P01S	12 pcs	Wood Screw
21	2250P04	5 pcs	Knob w/ Screw	23	2250P01WD	2 pcs	Wood Dowel

**PLEASE NOTE:** Assembly requires two people. Follow directions step by step.

**Step:01** - Carefully lay out all pieces on a padded surface to prevent damage. Take extra care when removing the door unit from the carton. Doors must be secured so they will not fall open.

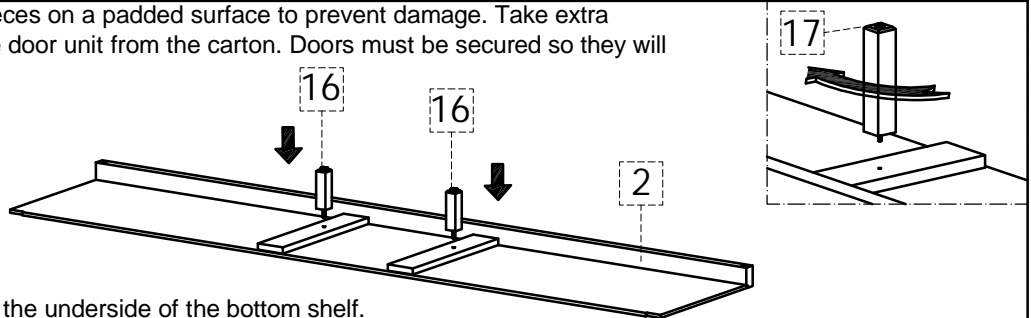

**Step:02**

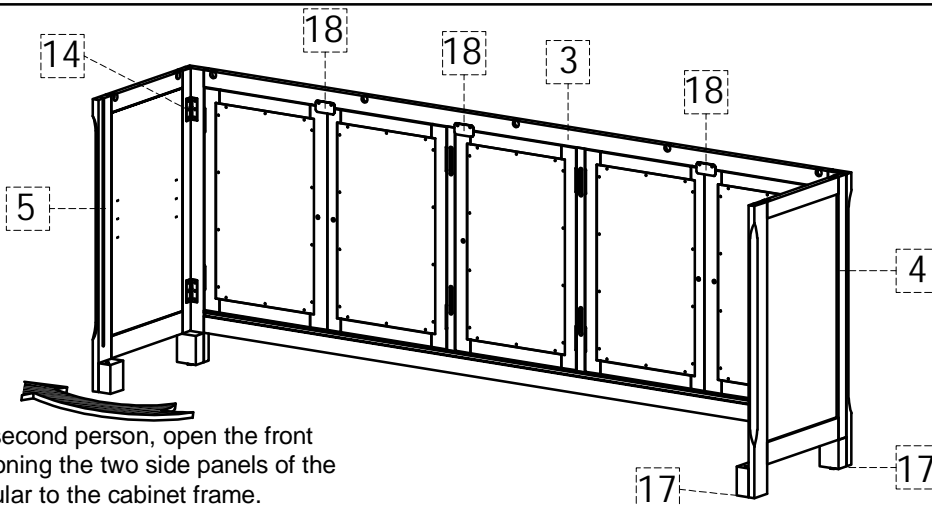

### Step:03

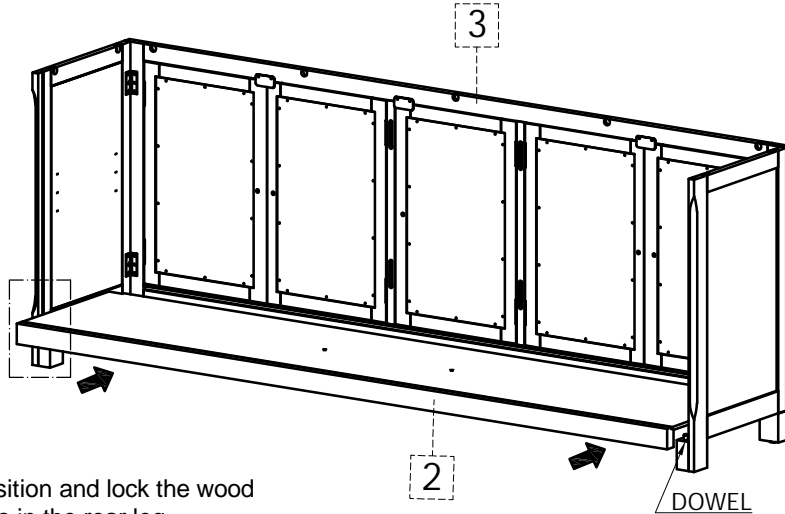
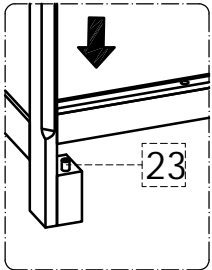

- Place the bottom shelf in position and lock the wood dowels into the receiving holes in the rear leg.

### Step:04

- Insert the Left and Right Vertical Partition by placing the tab on the panel into the receiver on the Front Frame and gently push down to lock into place. Make sure that the locking tab is in the opened position to insert into the bottom shelf.

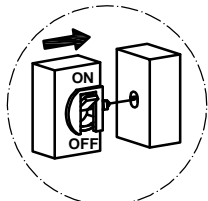
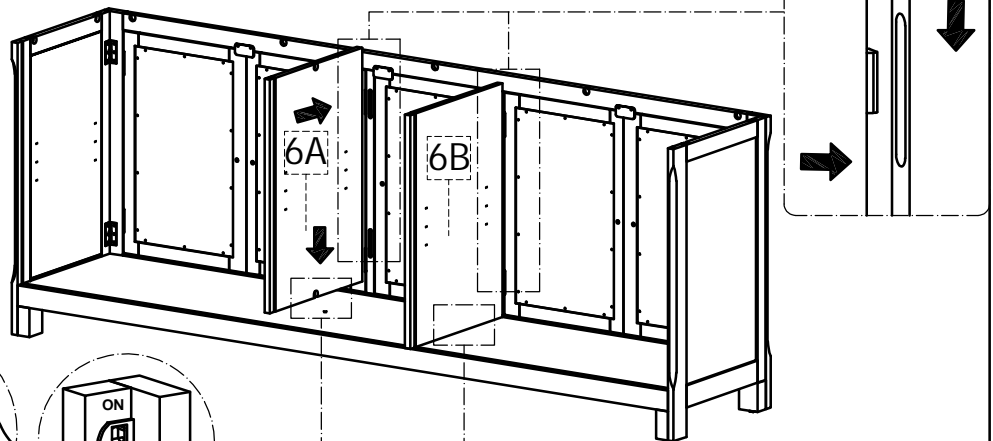

Tab in opened position

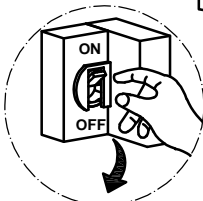

Pull tab down to lock



Tab in locked position

- Lock the tab ( see diagram below ) to secure the vertical panel to the bottom shelf

### Step:05

- Carefully insert the back panels into place making sure that the lock tabs are in the open position on the bottom of the back panel.  
- Once in place, lock the tabs on the bottom.

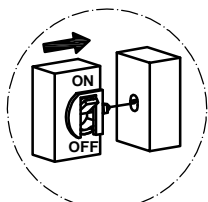
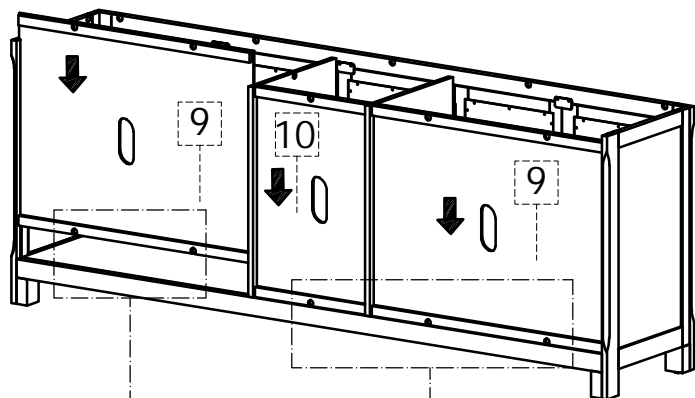

Tab in opened position

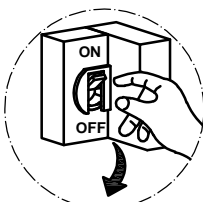

Pull tab down to lock



Tab in locked position

#### Step:06

- Line up all the locking tabs in the open position
- With two people, carefully align the top in place making sure that the tab fits into the receiver portion on the top. Once firmly in place, lock the tabs.

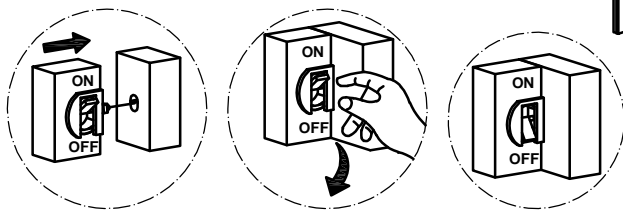

Tab in opened position    Pull tab down to lock    Tab in locked position

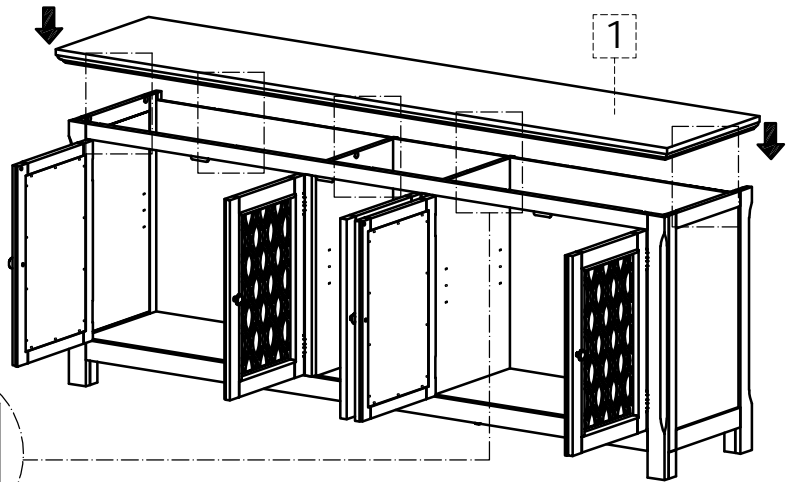

#### Step:07

- Install the shelves using the shelf pins. it is important to secure the shelf in place with the
- Attach the door pull with a Phillips screwdriver as shown

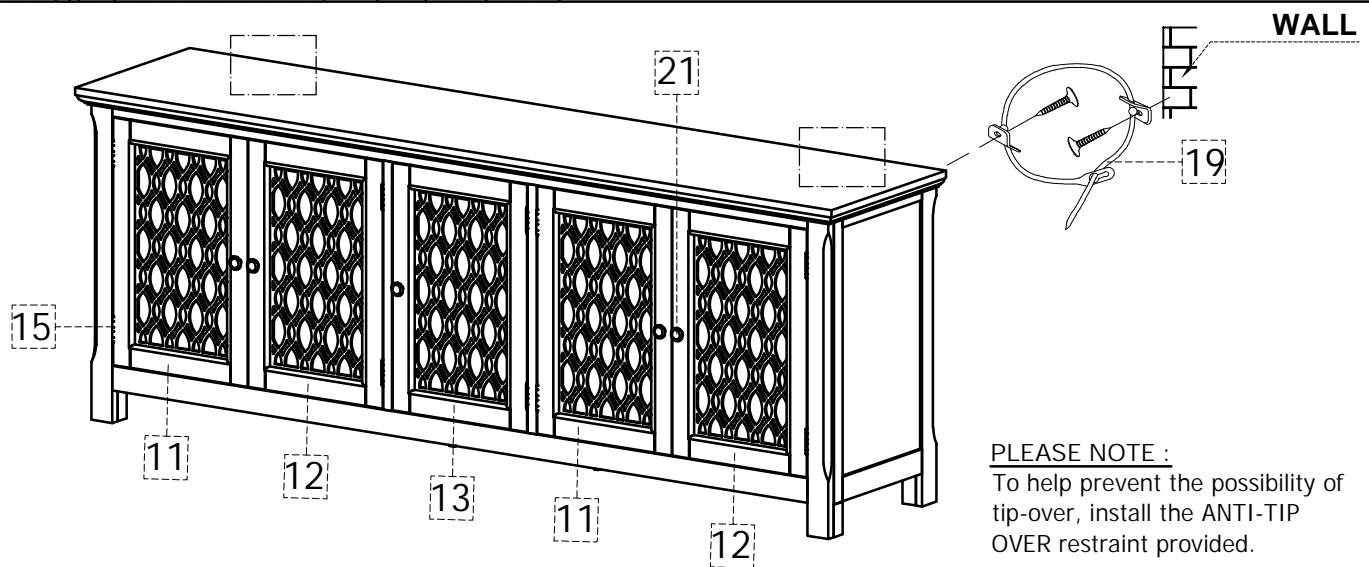
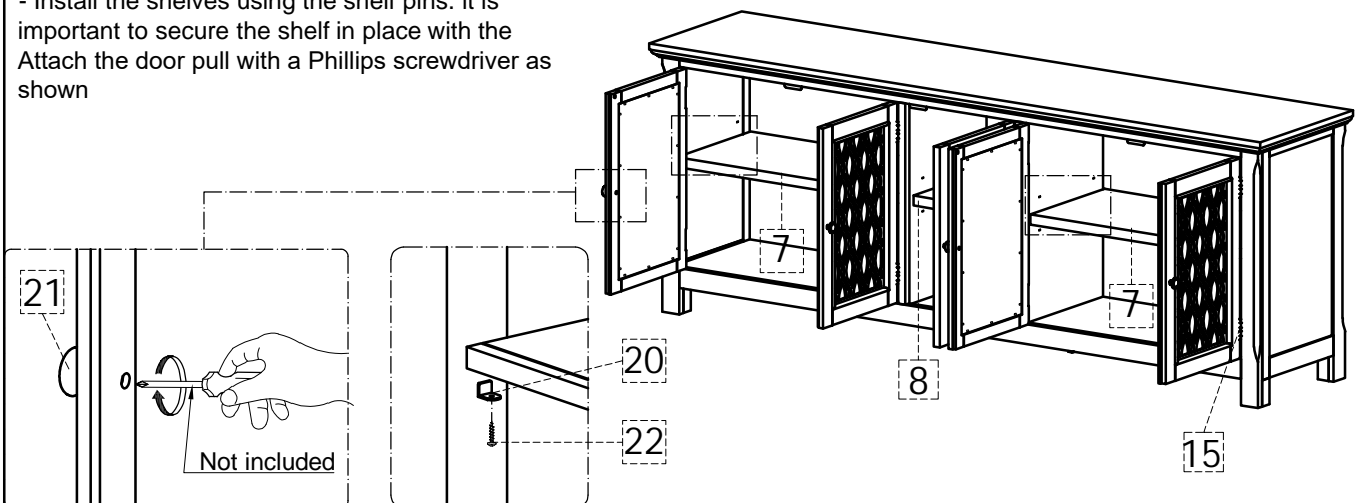

**PLEASE NOTE :**  
To help prevent the possibility of tip-over, install the ANTI-TIP OVER restraint provided.