







ASSEMBLY INSTRUCTIONS & PARTS IDENTIFICATION MODEL # 2231 - BS405KD TELLURIDE DRIFTWOOD UPH COUNTER STOOL

Thank you for purchasing this quality product. Be sure to check all packing material carefully for small parts that may have come loose inside the carton during shipment. DO NOT use power tools to assembly.

Parts key				Hardware Kit 2231-BS405KD46P01			
No	Code	Qty	Description	No	Code	Qty	Description
1		1 pc	Chair Back	A		4 pcs	Long Bolt Ø7.8 x 80mm
2	2231-BS405KDP41	1 pc	Complete Seat	B		4 pcs	Medium Bolt Ø7.8 x 50mm
3	2231-BS405KDP42	1 pc	Right Facing Front Leg	C		3 pcs	Short Bolt Ø7.8 x 35mm
4	2231-BS405KDP43	1 pc	Left Facing Front Leg	D		11 pcs	Lock Washer Ø8.5
5	2231-BS405KDP44	1 pc	Right Facing Side Stretcher	E		11 pcs	Flat Washer Ø8.5
6	2231-BS405KDP45	1 pc	Left Facing Side Stretcher	F		4 pcs	Allen Key
7	2231-BS405KDP49	1 pc	Front Stretcher	G		6 pcs	Screw Ø4x40mm
8	2231P01F	4 pcs	Floor glide				

STEP:01 - Carefully lay the Chair Back flat on a smooth flat surface to prevent scratches.

- Attach Complete Seat to Chair Back by inserting a Flat Washer (E), Lock Washer (D) with Short Bolt (C) into each of the hole on the back rail of the seat. Attach the Long Bolt(A), Lock Washer (D) and Flat Washer (E) into each of 2 holes in the Complete Seat corners. (See Detail A & B).

- Tighten screws with provided Allen Key (F) by turning clockwise until secure.

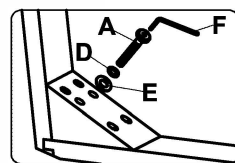

DETAIL B

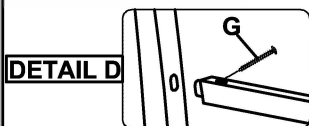
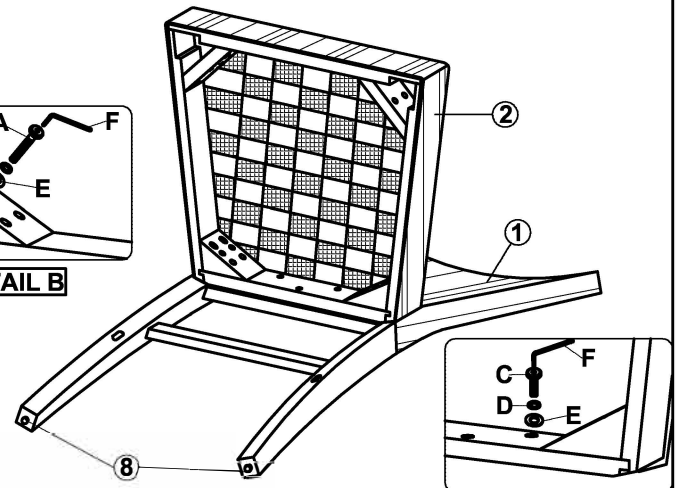

DETAIL D

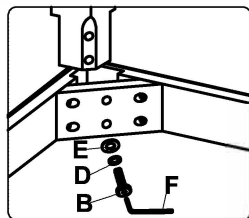

DETAIL C

STEP:02

- Carefully turn Chair upside down and attach each Leg to the front corners of the Complete Seat making note of the right side facing and the left side facing leg. The stretcher holes for the front stretcher are lower than the side.

- Attach the legs with a Flat Washer (E), Lock Washer (D) and Bolt (B) using the Allen Key (F).

- Do not fully tighten the Bolts at this stage until all the parts are in position (See Detail C).

- Insert 2 Side Stretchers between the Front Legs, fasten by hand with Wood Screw (G) using a phillip-head screwdriver. (not provided). (See Detail D). Once in place, tighten all the leg bolts.

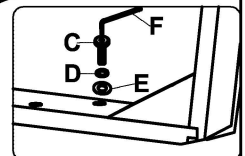

DETAIL A

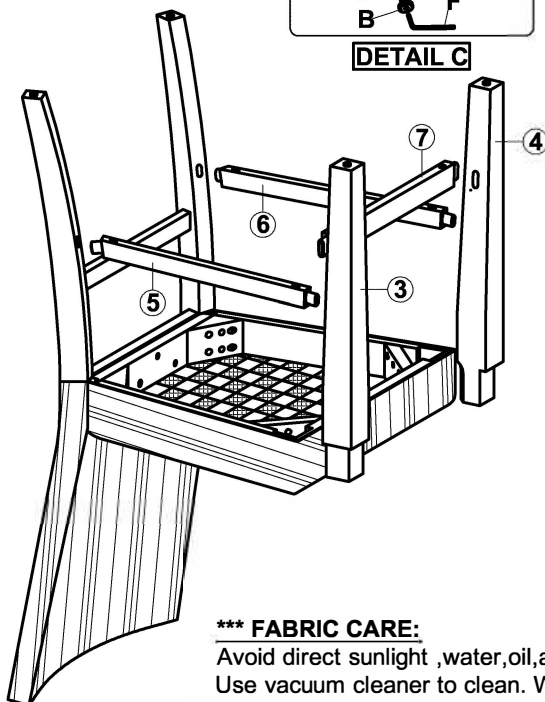

***** FABRIC CARE:**

Avoid direct sunlight ,water,oil,acid,sharp objects etc.
Use vacuum cleaner to clean. Wipe spills immediately.
If needed, spot clean with a mild water-based soap.
Fabric content 100% Polyester, Cleaning Code W

