

2201-DRAPERCHAIR

Hardware kit (2201-DRAPERP46)

Ltr	Qty	Description
A	1PC	BOLT ØM8X20MM
B	4PCS.	BOLT ØM8X35MM
C	4PCS.	FLAT WASHER
D	1PC	ALLEN WRENCH
E	4PCS.	LOCK WASHER

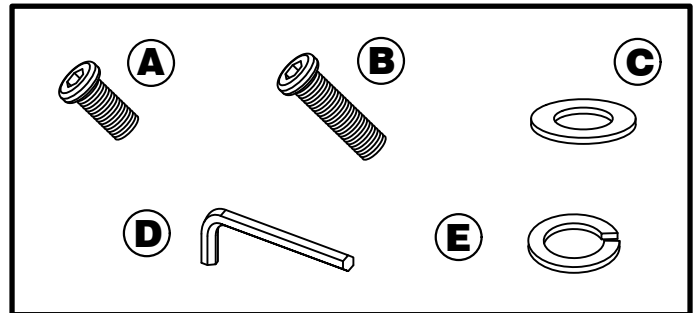

Parts Key

No	Code	Qty	Description
1	2201-DRAPERP43	1PC	UPPER LEG ASSEMBLY
2	2201-DRAPERP42	1PC	LOWER LEG ASSEMBLY
3	2201-DRAPERP01L	4PCS	FLOOR LEVELER

STEP 1:

. Carefully place the upper and lower leg assemblies together (noting the front and back position) upside down to prevent scratches on the legs as shown in Step 1.

. Connect the legs by inserting a bolt A.

. Do not fully tighten at this point

PLEASE NOTE: The upper leg has a threaded hole for the bolt and is labeled 1.(See diagram)

STEP 1:

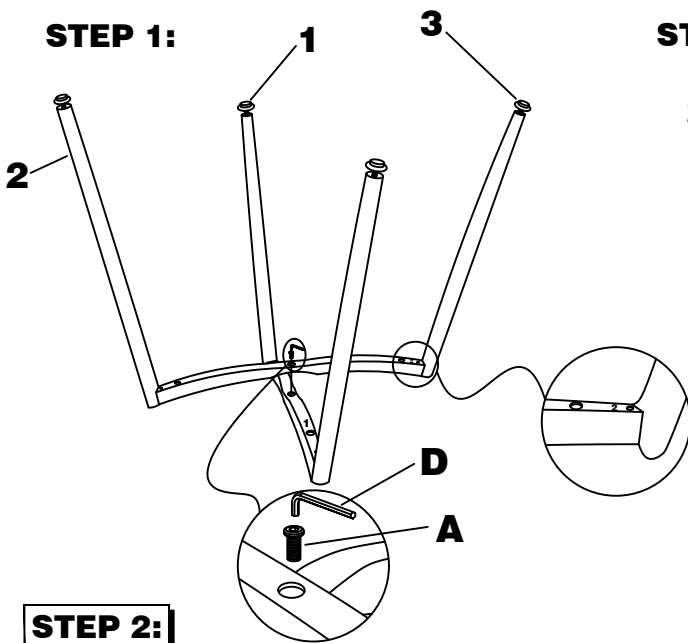

STEP 2:

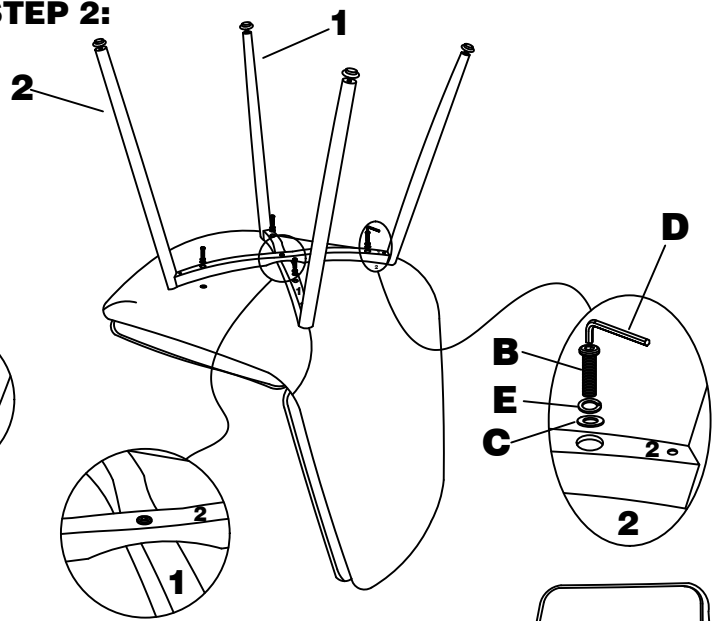

STEP 2:

. Attach the assembled legs to the seat by lining up the placement numbers and inserting a lock washer, a flat washer, and bolt B per the diagram. Do not fully tighten the bolts until all are in place.

. Once all bolts are in place, fully tighten the bolts by hand using the provided Allen Wrench. Do not use a power tool to tighten.

. Use the floor levelers to level the chair, if needed.

*** FABRIC CARE:

Avoid direct sunlight, water, oil, acid, sharp objects etc.

Use vacuum cleaner to clean. Wipe spills immediately.

Do not clean with water or any harsh detergents.

Fabric content 100% Polyurethane, Cleaning code X

