

Thank you for purchasing this quality product. Be sure to check all packing material carefully for small parts that may have come loose inside the carton during shipment.

| Hardware kit (2148-46KDP46) | | |
|-----------------------------|--------|-------------------|
| No | Q'Ty | Description |
| A | 12 pcs | Lock Washer 5/16" |
| B | 12 pcs | Flat Washer 5/16" |
| C | 8 pcs | Bolt 1/4"x 2" |
| D | 4 pcs | Bolt 1/4"x 1.5" |
| E | 1 pc | Allen Key |

| Key Parts | | | |
|-----------|---------------|-------|-------------------|
| No | Code | Q'Ty | Description |
| 1 | 2148P01F | 6 pcs | Floor glide |
| 2 | | 1 pc | Bench Seat |
| 3 | 2148-46KDP42 | 4 pcs | Bench Corner Legs |
| 4 | 2148-46KDP42M | 2 pcs | Bench Middle Legs |

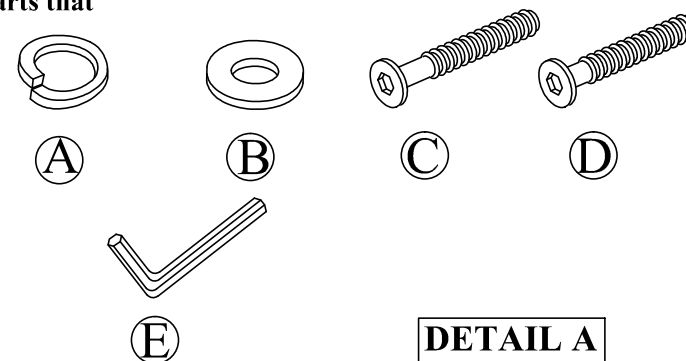

Remove bottom seat material before setup

STEP 1

- Carefully lay Bench seat up side down on a smooth flat surface to prevent scratches.
- Affix a leg (3), to each corner of the bench seat as shown in Detail (A) using a flat washer (B), lock washer(A) and bolt (C).
- Affix a middle leg (4) to the bench seat as shown in Detail (B) using a flat washer(B) , lock washer(A) and Bolt(D).

FABRIC CONTENT : 100% POLYESTER
CLEANING CODE "W"

Water-based cleaning agents or foam may be use.
Never use tap water. Use distilled water, as tap water contains minerals that may cause rings or fading. Pre-test on an inconspicuous area.

