







Thank you for purchasing this quality product. Be sure to check all packing material carefully for small parts that may have come loose inside the carton during shipment.

Key Parts			
No	Code	Description	Q'Ty
1	2146-BS420KDP40	Chair Back	1 pc
2	2146-BS420KDP41	Complete Seat	1 pc
3	2146-BS420KDP42	Right Side Facing Leg	1 pc
4	2146-BS420KDP43	Left Side Facing Leg	1 pc
5	2146-BS420KDP44	Right Side Facing Stretcher	1 pc
6	2146-BS420KDP45	Left Side Facing Stretcher	1 pc
7	2146-BS420KDP49	Front Stretcher	1 pc
8	2146-BS420KDP01F	Floor glide	4 pcs

Hardware kit (2146-BS420KDP46)			
No		Description	Q'Ty
A		Hexa Nut Ø5/16"	4 pcs
B		Lock Washer Ø5/16"	11 pc
C		Flat Washer Ø5/16"	11 pc
D		Long Bolt 1/4" x 3"	4 pc
E		Short Bolt 1/4" x 1.5"	3 pc
F		Allen Key	1 pc
G		Key Wrench	1 pc
H		Screw Ø4 x 38mm	6 pcs

### STEP 1

- Carefully lay Chair Back flat on a smooth flat surface to prevent scratches.
- Affix Complete Seat to Chair Back by inserting a Flat Washer (C), Lock Washer (B) with Short Bolt (E) into each of the hole on the back rail of the seat, and Long Bolt (D) with washes into each of 2 holes in the Complete Seat corners. (See Detail A & B).
- Tighten screws with provided Allen Key (F) by turning clockwise until secure

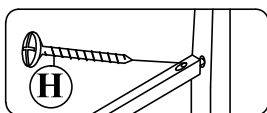
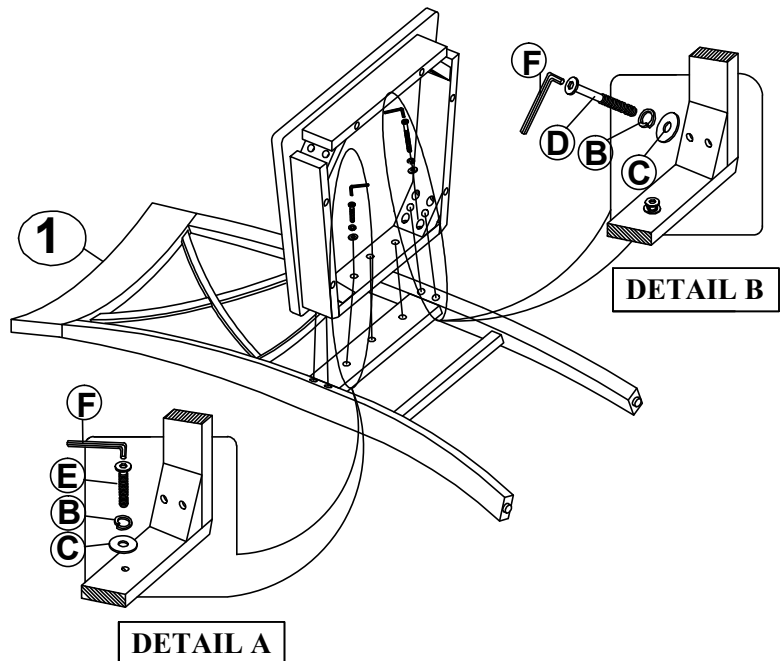

DETAIL D

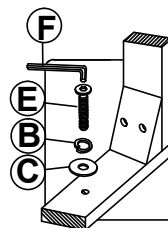

DETAIL A

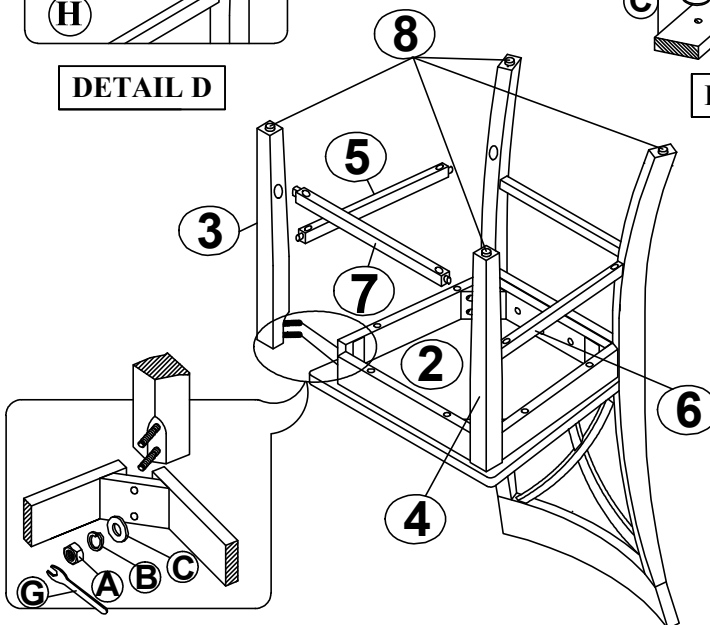

DETAIL C

### STEP 2

- Carefully turn chair upside down and attach each Front Leg to the front corners of the Complete Seat (Keeping in mind of the right side and left side leg) with a Flat Washer (C), Lock Washer (B) and Nut (A). (See detail C). Keep nut loose at this point. Insert right side stretcher and left side stretcher between the Front and Back Legs, then insert the Front Stretcher between the two Front Legs. (Make sure that the side stretchers are not at an angle as the front legs are on the wrong side). Fasten stretchers to legs with Screws (H) using a Screwdriver (not provide).
- Be sure to level the chair prior to tightening front leg nuts with wrench provided (G).