





Thank you for purchasing this quality product. Be sure to check all packing material carefully for small parts that may have come loose inside the carton during shipment.

Parts key				Hardware kit # 2092-1P01				
No	Code	Qty	Description	No	Description			Qty
1	2092-1P54	1 pc	Table Top	A		Bolt	Ø6 x 30	26 pcs
2	2092-1P29	1 pc	Mounting Plate	B		Lock washer	Ø8	26 pcs
3	2092-1P08	1 pc	Base Shelf	C		Flat washer	Ø8 x 18	26 pcs
4	2092-1P02E	2 pcs	End Leg	D		Allen key	K4	01 pc
5	2092-1P02M	8 pcs	Middle Leg (Hole in center for part 6)	STEP 2				
6	2092-1P11	1 pc	Connecting Rod					
7	2092P03	4 pcs	Casters with Screws					

Please Note : Assembly requires two people

STEP 1

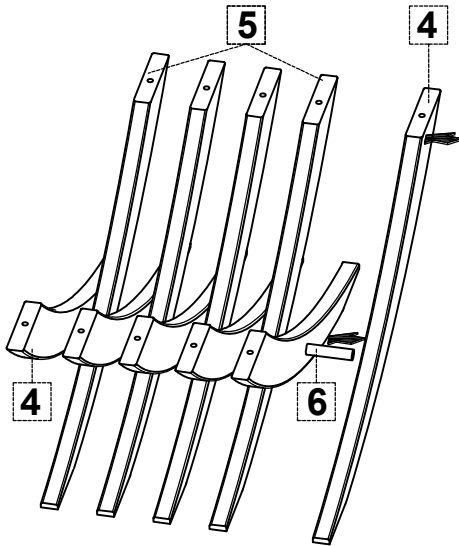

STEP 1: ASSEMBLING THE LEG UNIT

- Separate the two End Leg pieces (Part 4) from the eight Middle Leg pieces with the hole in the center (Part 5).
- Arrange the legs so that the thinner end of the legs are going in the same direction.
- Build the leg assembly by inserting the Connecting Rod through the center hole in the middle legs, keeping the thinner end up.
- Complete the assembly with the two end pieces and hold together.

STEP 2: ATTACHING THE LEGS TO THE MOUNTING PLATE

- Place the mounting Plate (Part 2) over the thinner leg ends and attach using a Bolt, Lock Washer and Flat Washer (see diagram) into each of the holes. Tighten with the Allen key provided.

STEP 3: ATTACHING THE MOUNTING PLATE TO THE TABLE TOP

- Place the table top on a smooth padded surface to prevent scratches or damage.
- Attach the Mounting Plate with the attached Legs using a Bolt, Lock Washer and Flat washer (see diagram).
- Attach the Table Base to the legs as shown using a Bolt, Lock Washer and Flat Washer.
- Tighten all bolts securely before turning table upright.

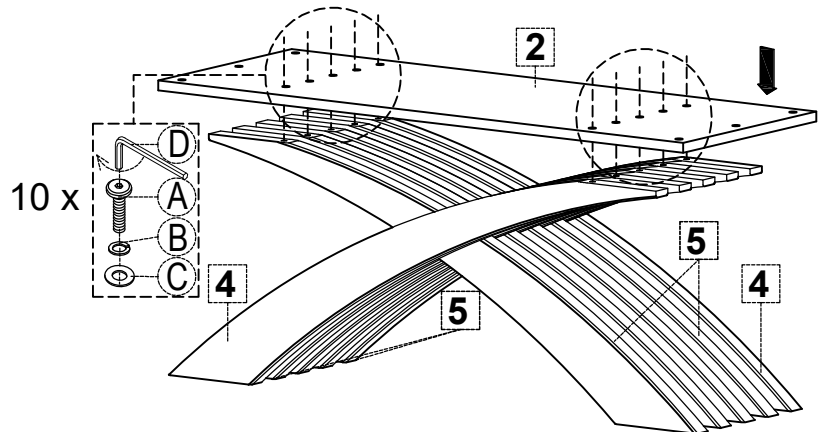

STEP 3

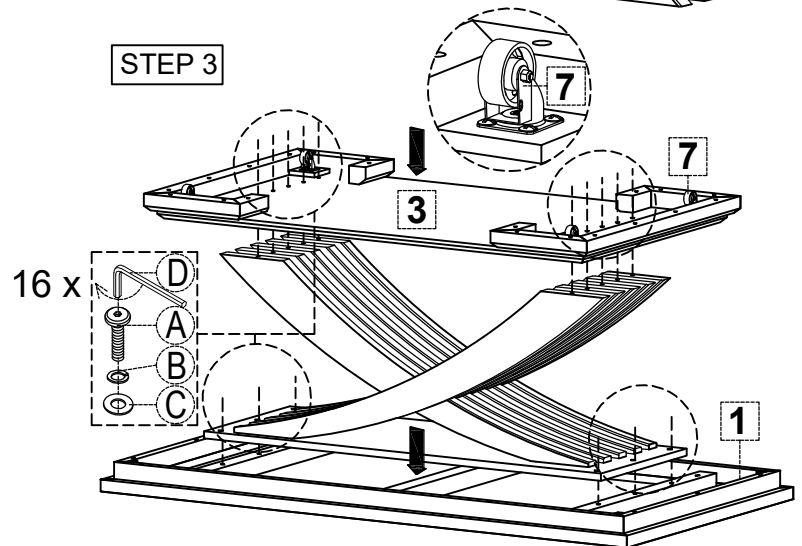

FINISH

