

Thank you for purchasing this quality product. Be sure to check all packing material carefully for small parts that may have come loose inside the carton during shipment.

Hardware kit (2021-56KDP46)		
No	Q'Ty	Description
A	12 pcs	Lock Washer 5/16"
B	12 pcs	Flat Washer 5/16"
C	12 pcs	Bolt 1/4"x 1 3/4"
D	1 pc	Allen Key
E	6 pcs	Screw Ø4 x 38mm

Key Parts			
No	Code	Q'Ty	Description
1	2021P01F	6 pcs	Floor glide
2	2021-56KDP41	1 pc	Bench Seat
3	2021-56KDP42	2 pcs	Right Facing Front Leg
4	2021-56KDP43	2 pcs	Left Facing Front Leg
5	2021-56KDP42M	2 pcs	Middle Leg
6	2021-56KDP44	3 pcs	Stretcher

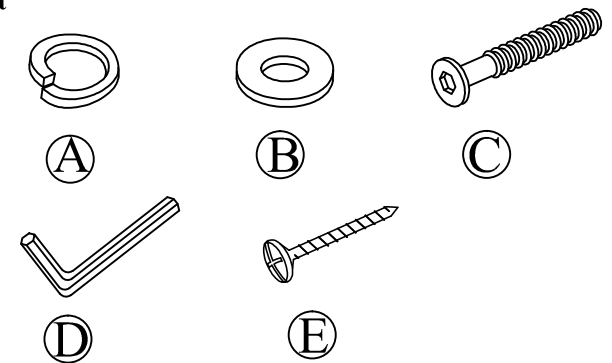

Remove bottom seat material before setup

STEP 1

- Carefully lay Bench seat up side down on a smooth flat surface to prevent scratches.
- Affix a leg (3), to each corner of the bench seat as shown in Detail (A) using a flat washer, lock washer ,long Bolt.Do not fully tighten the Bolts at this point.
- Affix a middle leg (4) to the bench seat as shown in Detail (B) using a flat washer, lock washer and short Bolt. Do not fully tighten the Bolts at this point.
- Insert 4 long stertcher then insert 3 short stretcher between side leg and middle leg, faster stretchers with screw using Screwdriver (not provide). (Detail C).
- After all the stretchers are in place, tighten all Bolts.
- Replace bottom seat material.

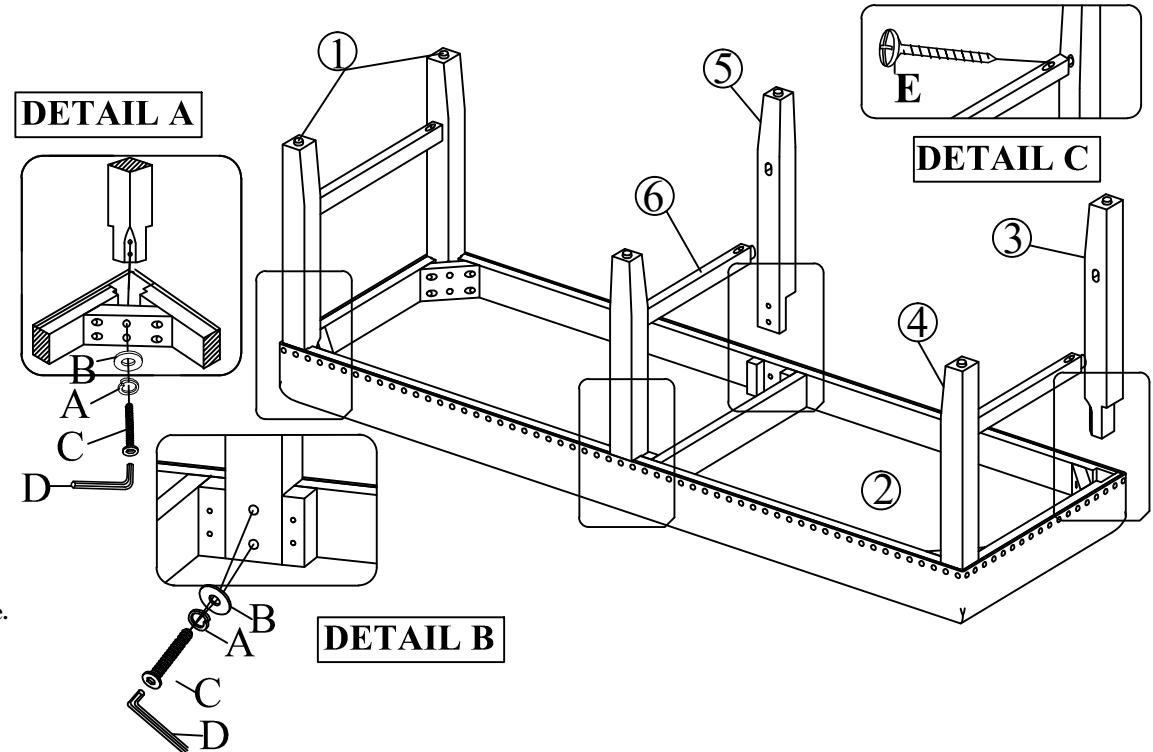

FABRIC CARE INSTRUCTION REGULAR CARE

Clean with shampoo, foam, or dry cleaning solvents as desired.
Do not saturate with liquid. Pile fabrics may require brushing to restore appearance.
Cushion covers should not be removed and dry cleaned.
FABRIC CONTENT: 100% Polyester; Cleaning code "WS"