

Hardware Kit (1976-3P01)			
Ltr	Q'ty	Description	Size
A	1 pc	Allen wrench	4mm
B	8 pcs	Bolt	Ø1/4" * 2 1/8"
C	8 pcs	Lock washer	Ø1/4"
D	8 pcs	Flat washer	Ø1/4" * 19mm
E	4 pcs	Screw	Ø8" * 1-1/2"

Part List			
No.	Parts	Description	Q'ty
①	1976-3P02	Leg	4 pcs
②	1976-3P08	Shelf	1 pc
③	1976-3P51	Storage Box	1 pc
④	1976-3P05	Drawer	1 pc
⑤	1976P01F	Floor Glide	4 pcs
⑥	1976P04	Knob/Screw	1 set
⑦	1976P05A	Drawer Stop	1 pc
⑧	1976-3P06	Drawer Glide	1 pc
⑨	1976P06D	Drawer Support	1 pc

STEP 3 : ▼

Insert the shelf between the three legs. Add the fourth leg and secure with a bolt, lock washer and flat washer.

Secure the shelf to the legs using screws (E). Once the shelf is in place fully tighten all bolts and screws.

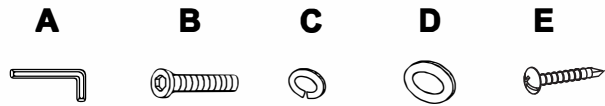
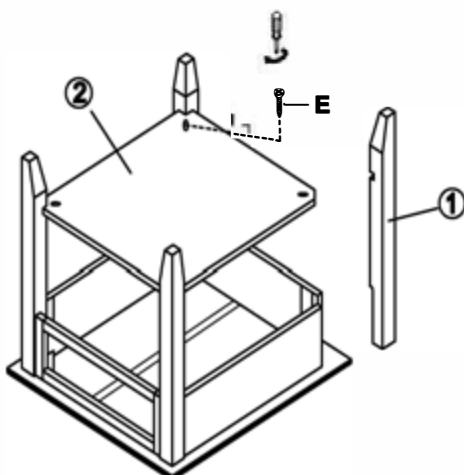

STEP 1 : ▼

First pull out the drawer, remove the drawer by pushing down on the plastic drawer stop and gently pulling out the drawer.

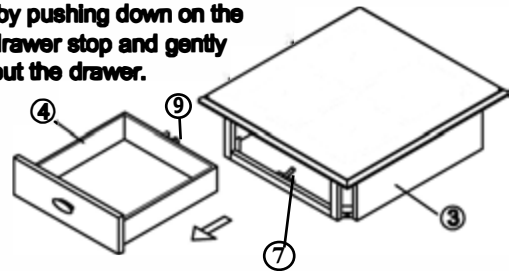

STEP 2 : ▼

Carefully place the table top upside-down on a smooth, flat surface to prevent scratches during assembly.

Attach three legs to the table top with Allen bolt (B), Lock washer (C) and Flat washer (D), loosely tightening with provided Allen wrench (A). Do not completely tighten bolts at this point.

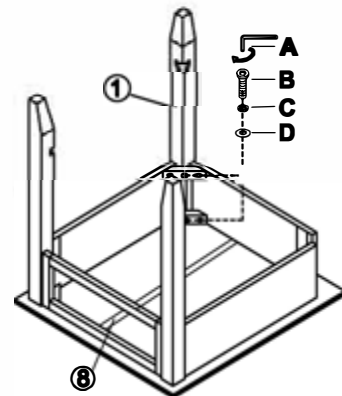

STEP 4 : ▼

Carefully turn the assembled table the upright position. Put back the drawer. Assembly is now complete.

