

Thank you for purchasing this quality product. Be sure to check all packing material carefully for small parts that may have come loose inside the carton during shipment.

Hardware kit (1933-BS52KDP46)		
No	Q'Ty	Description
A	12 pcs	Lock Washer 5/16"
B	12 pcs	Flat Washer 5/16"
C	12 pcs	Bolt 1/4" x 2"
D	1 pc	Allen Key
E	14 pcs	Screw Ø4 x 38mm

Key Parts			
No	Code	Q'Ty	Description
1	1933P01F	6 pcs	Floor glide
2	1933-BS52KDP41	1 pc	Bench Seat
3	1933-BS52KDP42	2 pcs	Bench Leg Right
4	1933-BS52KDP43	2 pcs	Bench Leg Left
5	1933-BS52KDP42M	2 pcs	Bench Middle Leg
6	1933-BS52KDP44BL	4 pcs	Long Bench Stretcher
7	1933-BS52KDP44BS	3 pcs	Short Bench Stretcher

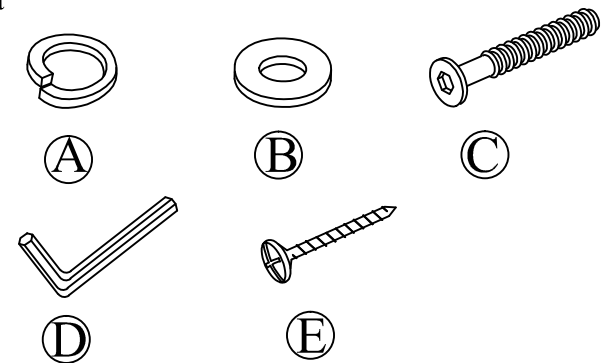

Remove bottom seat material before setup

STEP 1

- Carefully lay Bench seat up side down on a smooth flat surface to prevent scratches.
- Affix a leg (3), to each corner of the bench seat as shown in Detail (A) using a flat washer, lock washer, bolt. Do not fully tighten the Bolts at this point.
- Affix a middle leg (4) to the bench seat as shown in Detail (B) using a flat washer, lock washer and Bolt. Do not fully tighten the Bolts at this point.
- Insert 4 long stretcher then insert 3 short stretcher between side leg and middle leg, faster stretchers with screw using Screwdriver (not provide). (Detail C).
- After all the stretchers are in place, tighten all Bolts.
- Replace bottom seat material.

DETAIL A

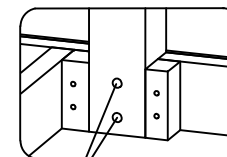
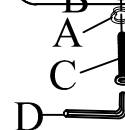
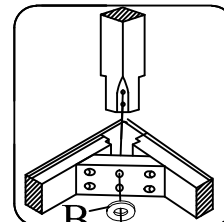

DETAIL B

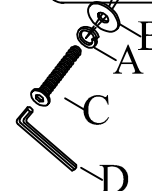

DETAIL C

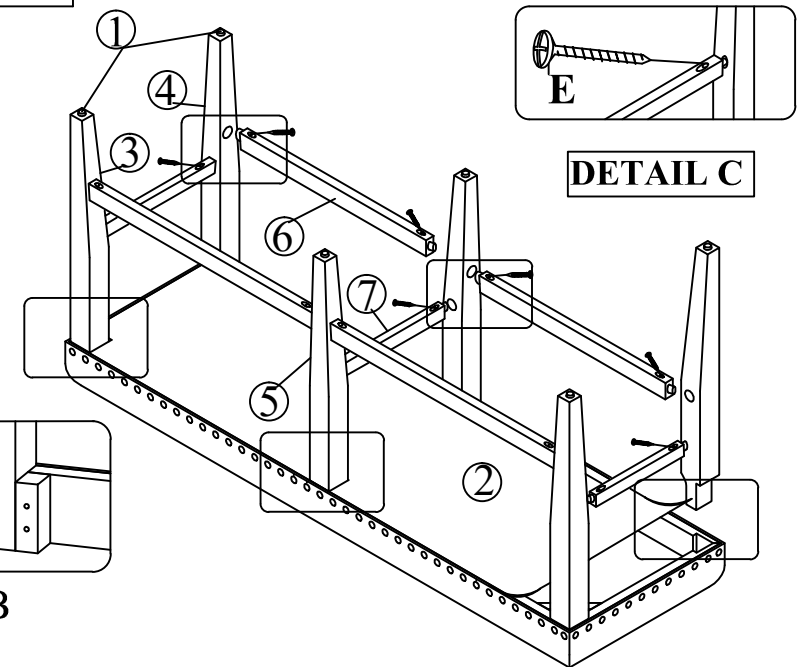

FABRIC CARE : CLEANING CODE "S"

Clean only with dry cleaning slovent ,do not saturate.Do not use water.

Pile fabrics may require brushing to restore appearance.

FABRIC CONTENT:55% Cotton; 45% Linen