

Hardware kit (1931-74P01)		
No	Description	Q'Ty
A	Long Bolt 1/4"x 2 3/4"	3 pcs
B	Medium Bolt 1/4"x 2"	4 pcs
C	Short Bolt 1/4"x 1.5"	10 pcs
D	Lock washer 5/16"	17 pcs
E	Flat washer 5/16"	17 pcs
F	Allen Key Ø4	1 pc
G	Wooden Button	4 pcs

Parts Key			
No	Code	Q'Ty	Description
1	1931-74P54	1 Pc	Table Top
2	1931-74P53	2 Pcs	Leg Assembly
3	1931-74P11B	1 Pc	Back Stretcher
4	1931-74P11U	1 Pc	Upper Stretcher
5	1931P01F	4 Pcs	Floor Glide

STEP 1

- Insert Upper Stretchers between the legs, using Flat Washer (E), Lock Washer (D) and medium bolt (B).
- Tighten screws with provided Allen Key (F) by turning clockwise until secure. (See Detail A).

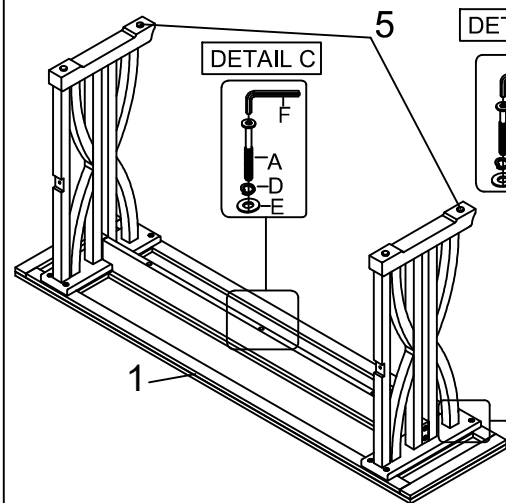

STEP 3

- Insert Upper Stretchers between the Back Stretcher, using Flat Washer (E), Lock Washer (D) and short bolt (C) (See Detail D).
- Insert Wooden button (G) to bottom frame. (See Detail E).

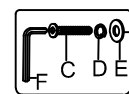

DETAIL D

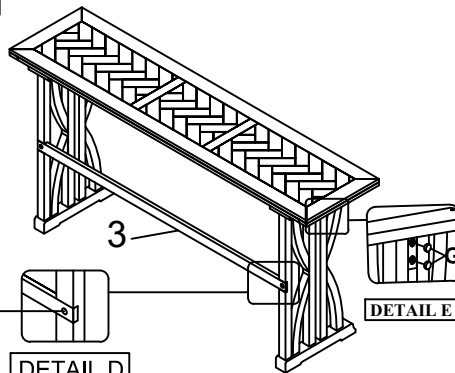

DETAIL E

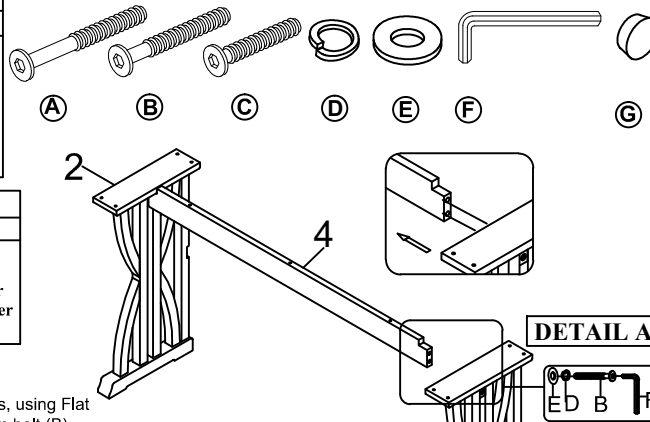

DETAIL A

DETAIL B

STEP 2

- Carefully lay Table Top upside down on a smooth flat surface to prevent scratches.
- Affix bottom frame to the Table Top as shown in illustration. Insert a Flat Washer (E), Lock Washer (D) and short bolt (C).
- Insert a Flat Washer (E), Lock Washer (D) and long bolt (A) for upper stretcher.
- Tighten screws with provided Allen Key (F) by turning clockwise until secure. (See Detail B & C).

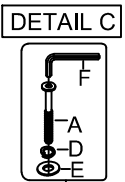

DETAIL C

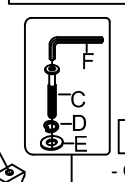

DETAIL B

Hardware kit (1931-74P46)		
No	Description	Q'Ty
A	Bolt 1/4" x 2"	24 pcs
B	Lock washer 5/16"	24 pcs
C	Flat washer 5/16"	24 pcs
D	Screw Ø4 x 38mm	24 pcs
E	Allen Key Ø4	1 pc

Parts Key			
No	Code	Q'Ty	Description
6	1931-74P41	1 pc	Complete Seat
7	1931-74P42	2 pcs	Right Side Facing Leg
8	1931-74P43	2 pcs	Left Side Facing Leg
9	1931-74P44S	2 pcs	Small Side Stretcher
10	1931-74P49	2 pcs	Front/ Back Stretcher
11	1931P01F	4 pcs	Floor Glide

FABRIC CARE : CLEANING CODE "S"
Clean only with dry cleaning slovent ,do not saturate.Do not use water.
Pile fabrics may require brushing to restore appearance.
FABRIC CONTENT:55% Cotton; 45% Linen

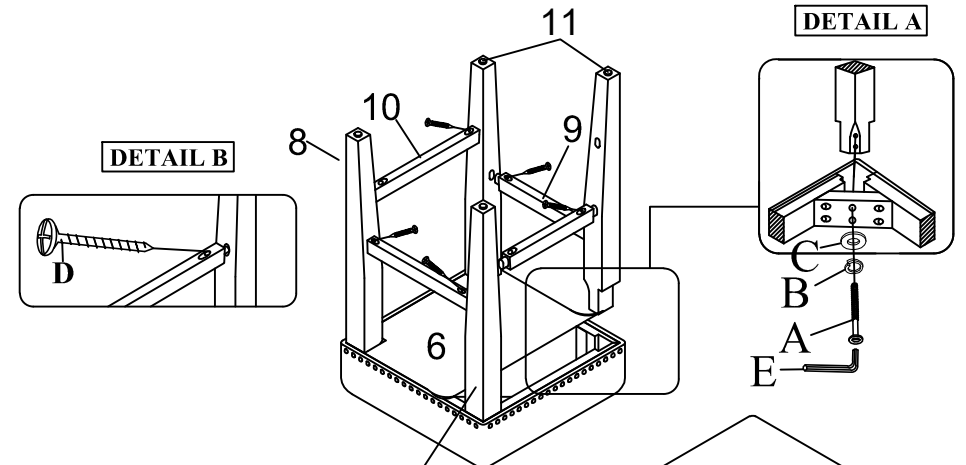

STEP 1

- Carefully lay the stool seat upside down on a smooth flat surface to prevent scratches.
- Affix a leg to each corner of the stool seat, noting the left side and right side, using a flat washer , lock washer and bolt . (See Detail A) Do not fully tighten at this point.
- Insert the 2 Long Stretchers then insert the Short Stretchers between the legs; fasten with Wood Screw using phillip-head screwdriver. (not provided).(See Detail B)
- Once all Stretchers are in place, fully tighten the bolts.

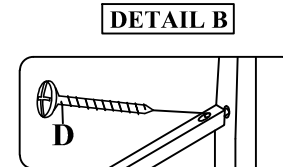

DETAIL B

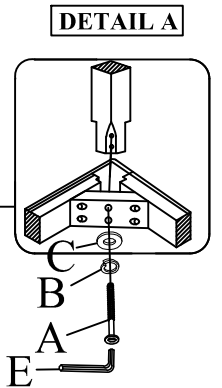

DETAIL A

