

Hardware kit (1921-74P01)		
No	Description	Q'Ty
A	Long Bolt 1/4"x 2"	2 pcs
B	Short Bolt 1/4"x 1 3/8"	10 pcs
C	Lock washer 5/16"	12 pcs
D	Flat washer 5/16"	12 pcs
E	Allen Key Ø4	1 pc
F	Wooden button	2 pcs

Parts Key			
No	Code	Q'Ty	Description
1	1921-74P54	1 Pc	Table Top
2	1921-74P53	2 Pcs	Leg Assembly
3	1921-74P11B	1 Pc	Back Stretcher
4	1921-74P11U	1 Pc	Upper Stretcher
5	1921P01F	4 Pcs	Floor Glide

STEP 1

- Insert Upper Stretchers between the legs, using Flat Washer (D), Lock Washer (C) and long bolt (A).
- Tighten screws with provided Allen Key (E) by turning clockwise until secure. (See Detail A).

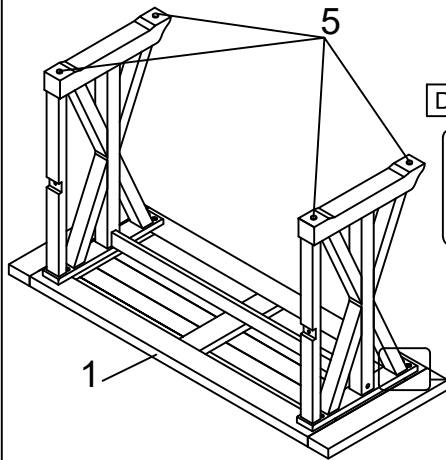
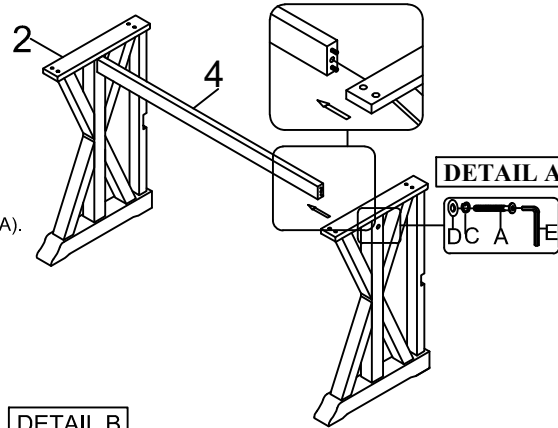
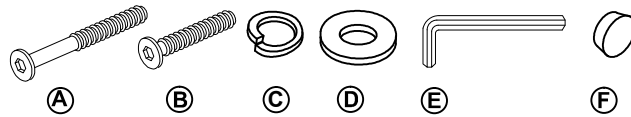

STEP 2

- Carefully lay Table Top upside down on a smooth flat surface to prevent scratches.
- Affix bottom frame to the Table Top as shown in illustration. Insert a Flat Washer (D), Lock Washer (C) and short bolt (B).
- Tighten screws with provided Allen Key (E) by turning clockwise until secure. (See Detail B).

STEP 3

- Insert Upper Stretchers between the Back Stretcher, using Flat Washer (D), Lock Washer (C) and short bolt (B) (See Detail C).
- Insert wooden button (F) to bottom frame. (See Detail D).

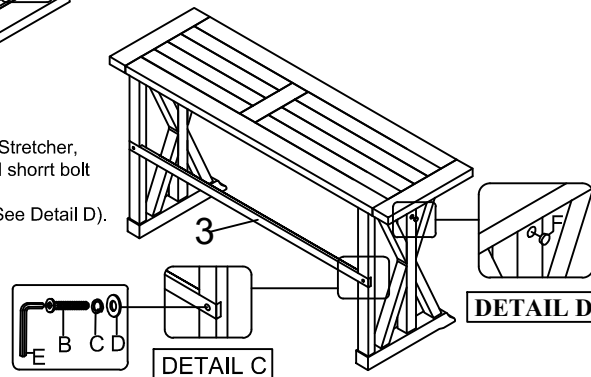

Hardware kit (1921-74P46)		
No	Description	Q'Ty
A	Bolt 1/4"x 2"	24 pcs
B	Lock washer 5/16"	24 pcs
C	Flat washer 5/16"	24 pcs
D	Screw Ø4 x 38mm	24 pcs
E	Allen Key Ø4	1 pc

Parts Key			
No	Code	Q'Ty	Description
6	1921-74P41	1 pc	Complete Seat
7	1921-74P42	2 pcs	Right Side Facing Leg
8	1921-74P43	2 pcs	Left Side Facing Leg
9	1921-74P44S	2 pcs	Small Side Stretcher
10	1921-74P49	2 pcs	Front/ Back Stretcher
11	1921P01F	4 pcs	Floor Glide

- FABRIC CARE INSTRUCTION REGULAR CARE
Clean with shampoo, foam, or dry cleaning solvents as desired.
Do not saturate with liquid. Pile fabrics may require brushing to restore appearance.
Cushion covers should not be removed and dry cleaned.
FABRIC CONTENT: 100% Polyester; Cleaning code "WS"

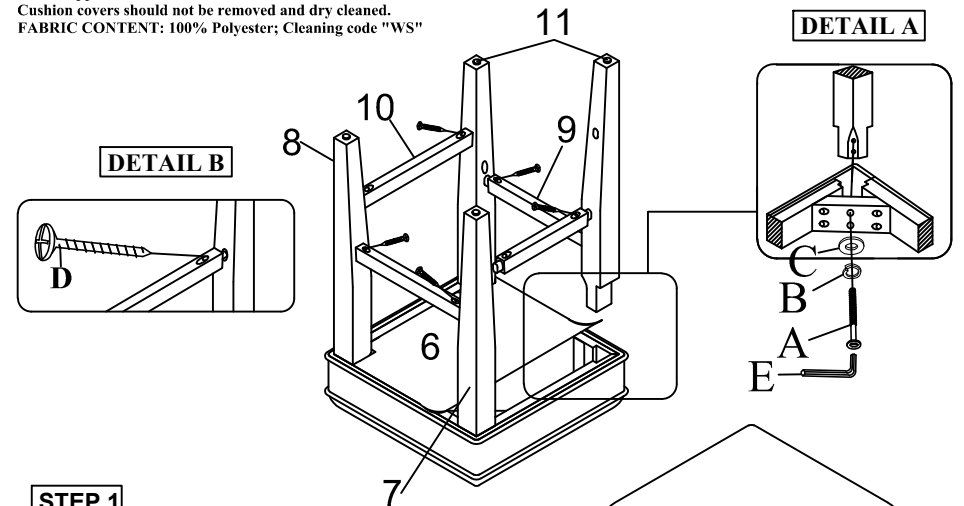
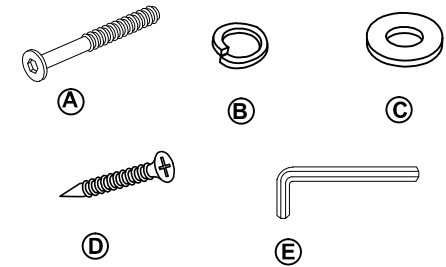

STEP 1

- Carefully lay the stool seat upside down on a smooth flat surface to prevent scratches.
- Affix a leg to each corner of the stool seat, noting the left side and right side, using a flat washer, lock washer and bolt. (See Detail A) Do not fully tighten at this point.
- Insert the 2 Long Stretchers then insert the Short Stretchers between the legs; fasten with Wood Screw using phillip-head screwdriver. (not provided). (See Detail B)
- Once all Stretchers are in place, fully tighten the bolts.

