

Thank you for purchasing this quality product. Be sure to check all packing material carefully for small parts that may have come loose inside the carton during shipment.

Hardware kit (1920-1TP01)			
No	Description		Q'Ty
A		Long Bolt 1/4"x 2"	2 pcs
B		Short Bolt 1/4"x 1 3/8"	4 pcs
C		Lock washer 5/16"	6 pcs
D		Flat washer 5/16"	6 pcs
E		Allen Key Ø4	1 pc

Parts Key			
No	Code	Description	Q'Ty
1	1920-1P54	Top	1 Pc
2	1920-1P53	Leg Assembly	2 Pcs
3	1920-1P11	Stretcher	1 Pc
4	1920-1P11C	Stretcher Cap	2 Pcs
5	1920-1P01F	Floor Glide	4 Pcs

STEP 1

- Insert Stretchers between the legs, using Flat Washer (D), Lock Washer (C) and long bolt (A),
- Tighten screws with provided Allen Key (E) by turning clockwise until secure. (See Detail A).

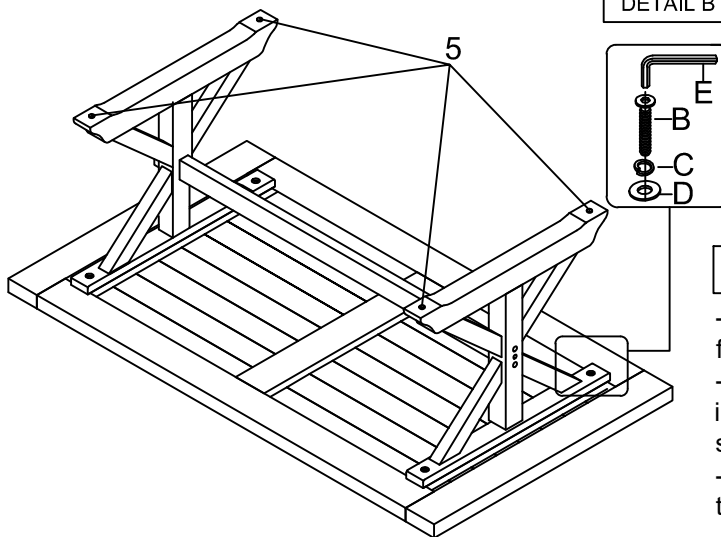
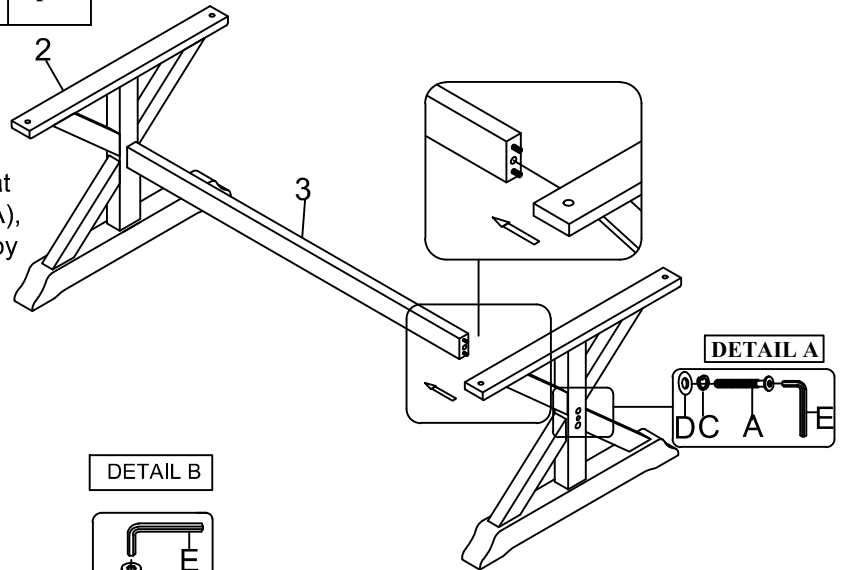

STEP 2

- Carefully lay Table Top upside down on a smooth flat surface to prevent scratches.
- Affix bottom frame to the Table Top as shown in illustration. Insert a Flat Washer, Lock Washer and short bolt (B).
- Tighten screws with provided Allen Key (E) by turning clockwise until secure. (See Detail B).

STEP 3

- Insert Stretcher Cap to bottom frame. (See Detail C).

