

# jOFRRAN INC.

## ASSEMBLY INSTRUCTIONS & PARTS IDENTIFICATION MODEL # 1886 5 PACK TABLE & CHAIRS

### 5-Pack Hardware Kit (1886P01)

Ltr	Qty	Description
A	8 pcs	Flat Washer 5/16"
B	8 pcs	Lock Washer 5/16"
C	8 pcs	Nut 5/16"
D	1 pc	Key Wrench

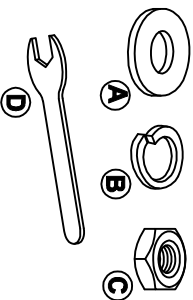

### Table Parts Key

No	Code	Qty	Description
1	1886P01FT	4 pcs.	Table/Floor Glide
2	1886P02	4 pcs.	Leg
3	1886P24	1 pc.	Table top

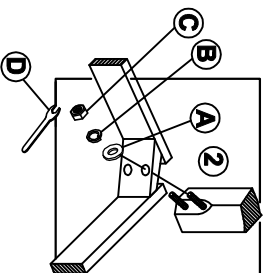

Detail A

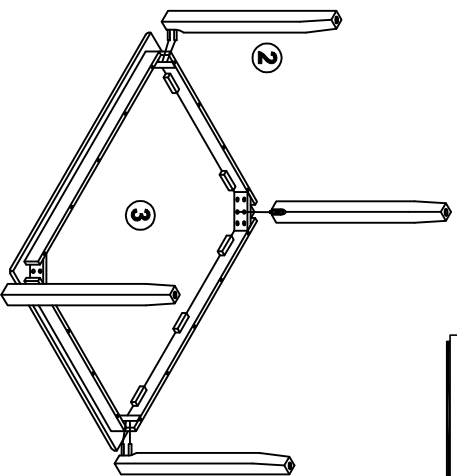

### STEP 1

- Carefully lay table top upside down on a smooth flat surface to prevent scratches.
- Affix a leg to each corner of the table top as shown in Detail A using a flat washer, lock washer and nut.
- Once all legs are in place, fully tighten the nuts

MADE IN VIET NAM

### 5-Pack Hardware Kit (1886P46)

Ltr	Qty	Description
A	44 pcs.	Flat Washer 5/16"
B	44 pcs.	Lock Washer 5/16"
C	16 pcs.	Nut 5/16"
D	4 pcs.	Key Wrench
E	16 pcs.	Long KD. Bolt 1/4" X 3".
F	12 pcs.	Short KD. Bolt 1/4" X 1.5".
G	4 pcs.	Allen Wrench
H	24 pcs.	Screw 1/6" x 1.5".

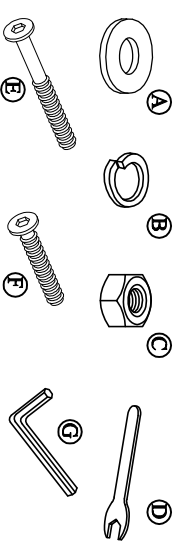

### STEP 1

- Carefully lay chair back flat on a smooth flat surface to prevent scratches.
- Affix the complete seat to chair back, as shown in Detail A using a flat washer, lock washer and short KD bolt.
- Secure complete seat to chair back corners, as shown in Detail B, using a flat washer, lock washer and long KD bolt. - - Tighten screws with provided Allen Wrench.

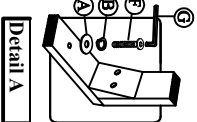

Detail A

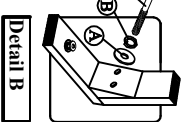

Detail B

No	Code	Qty	Description
5	1886P01FC	16 pcs.	Chair Floor Glide
6	1886P40	4 pcs.	Chair Back
7	1886P41	4 pcs.	Complete Seat
8	1886P42	4 pcs.	Right Facing Front Leg
9	1886P43	4 pcs.	Left Facing Front Leg
10	1886P44	4 pcs.	Right Facing Side Stretcher
11	1886P45	4 pcs.	Left Facing Side Stretcher
12	1886P49	4 pcs.	Front Stretcher

\*Quantities noted are for a total of four chairs.

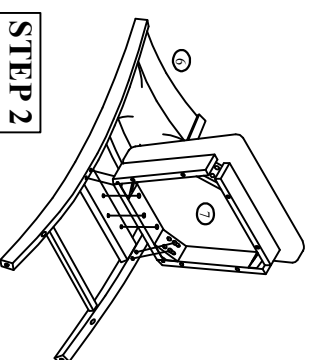

Detail C

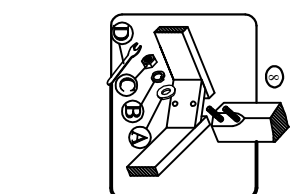

Detail A

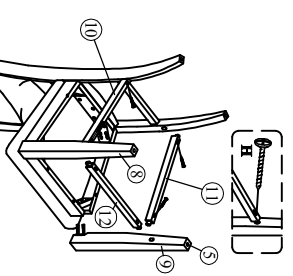

Detail D

### STEP 2

- Carefully turn Chair upside down and attach each Leg to the front corners of the Complete Seat. Noting Right and Left Side Leg.
- Place Flat Washer, Lock Washer and Nut on for each bolt, using provided Key Wrench.
- Do not fully tighten the Nuts at this stage until all the parts are in position (See Detail C).
- Insert 2 Side Stretchers between the Front Legs and Back Legs(Noting Right and Left Side Stretcher), and insert the Front Stretcher between the Front Legs; fasten with Wood Screw using phillip-head screwdriver. (not provided).(See Detail D)
- Be sure to tighten all screws and nuts prior to using Chair.

### FABRIC CARE INSTRUCTION REGULAR

CARE: Clean with shampoo, foam, or dry cleaning solvents as desired. Do not saturate with liquid. Pile fabrics may require brushing to restore appearance. Cushion covers should not be removed and dry cleaned.  
FABRIC CONTENT  
100% Polyester. Cleaning code "WS"