

Thank you for purchasing this quality product. Be sure to check all packing material carefully for small parts that may have come loose inside the carton during shipment.

Hardware kit (1872-BS385KDP46)			
No		Description	Q'Ty
A		Hexa Nut Ø8	4 pcs
B		Lock Washer Ø8	11 pc
C		Flat Washer Ø8	11 pc
D		Long Bolt Ø6 x 75mm	4 pc
E		Short Bolt Ø6 x 40mm	3 pc
F		Allen Key	1 pc
G		Key Wrench	1 pc
H		Screw Ø4 x 38mm	6 pcs

Key Parts			
No	Code	Description	Q'Ty
1	1872-BS385KDP40	Chair Back	1 pc
2	1872-BS385KDP41	Complete Seat	1 pc
3	1872-BS385KDP42	Right Facing Front Leg	1 pc
4	1872-BS385KDP43	Left Facing Front Leg	1 pc
5	1872-BS385KDP44	Right Facing Side Stretcher	1 pc
6	1872-BS385KDP45	Left Facing Side Stretcher	1 pc
7	1872-BS385KDP49	Front Stretcher	1 pc
8	1872-BS385KDP01F	Floor glide	4 pcs

STEP 1

- Carefully lay Chair Back flat on a smooth flat surface to prevent scratches.
- Affix Complete Seat to Chair Back by inserting a Flat Washer (C), Lock Washer (B) with Short Bolt (E) into each of the hole on the back rail of the seat, and Long Bolt (D) with washes into each of 2 holes in the Complete Seat corners. (See Detail A & B).
- Tighten screws with provided Allen Key (F) by turning clockwise until secure

STEP 2

- Carefully turn chair upside down and attach each Front Leg to the front corners of the Complete Seat (Keeping in mind of the right side and left side leg) with a Flat Washer (C), Lock Washer (B) and Nut (A). (See detail C). Keep nut loose at this point. Insert right side stretcher and left side stretcher between the Front and Back Legs, then insert the Front Stretcher between the two Front Legs. (Make sure that the side stretchers are not at an angle as the front legs are on the wrong side). Fasten stretchers to legs with Screws (H) using a Screwdriver (not provide).
- Be sure to level the chair prior to tightening front leg nuts with wrench provided (G).

FABRIC CARE INSTRUCTIONS

REGULAR CARE

Wipe gently using a clean soft damp cloth

and mild detergent **DO NOT SATURATE**

FABRIC CONTENT:
100% Polyurethane -
Cleaning code W

DETAIL D

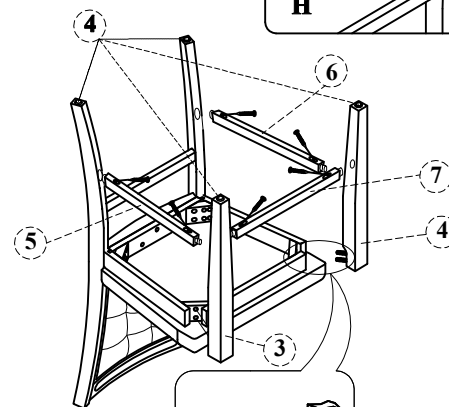
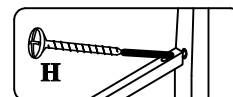

DETAIL B

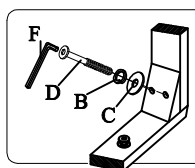

DETAIL C

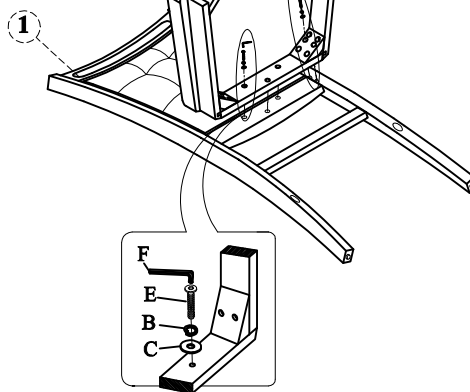
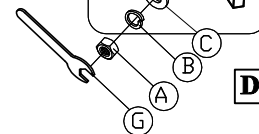

DETAIL A

