

ASSEMBLY INSTRUCTIONS & PARTS IDENTIFICATION MODEL # 1855 - 60 ALTAMONTE HIGH/LOW RECTANGLE TO SQUARE TABLE

Parts key				Hardware kit #1855-60P01			
No	Code	Qty	Description	No	Description	Qty	
1	1855-60P24	1 pc	Table Top	A	Hex nut M8	4 pcs	
2	1855-60P07	2 pcs	Sliding Door	B	Lock washer Ø8	24 pcs	
3	1855P04	2 pcs	Pull w/Screws	C	Flat washer Ø8 x 16mm	24 pcs	
4	1855P07S	4 sets	Sliding Wheel & Lock w/Screws - 2 pcs	D	Long bolt-Attaching Leg Extension 5/6" x 180mm	8 pcs	
5	1855-60P08T	1 pc	Storage Box Top Panel	E	Medium bolt Attaching Leg M6 x 60mm	8 pcs	
6	1855-60P08L	1 pc	Left Storage Box Shelf	F	Short bolt Attaching Top/Bottom Panel M6 x 30mm	4 pcs	
7	1855-60P08R	1 pc	Right Storage Box Shelf	G	Allen key K4	1 pc	
8	1855-60P08B	1 pc	Storage Box Bottom Panel	H	Key wrench 13	1 pc	
9	1855-60P02L	2 pcs	Left Facing Leg	I	Wooden Screw Ø4 x 25mm	8 pcs	
10	1855-60P02R	2 pcs	Right Facing Leg	J	Wooden Dowel Ø10 x 20mm	4 pcs	
11	1855-60P02E	4 pcs	Extensions Leg				
12	1855-60P08S	2 pcs	Storage Box Side Panel				
13	1855-60P08V	1 pc	Storage Box Vertical Panel				
14	1855-60P13	2 sets	Extension Mechanism				
15	1855-60P13L	4 sets	Extension Lock				
16	1855P01F	4 pcs	Floor Glide				

Step 1

Lay the top of the Storage Box upside down on a clean padded surface to prevent scratching. Insert the Wood Dowels (J) into the Vertical Panel ends.

Attach the Storage Box Vertical Panel to the Top Panel with a Short Bolt (F), a Lock Washer (B) and a Flat Washer (C) using the Allen key provided.

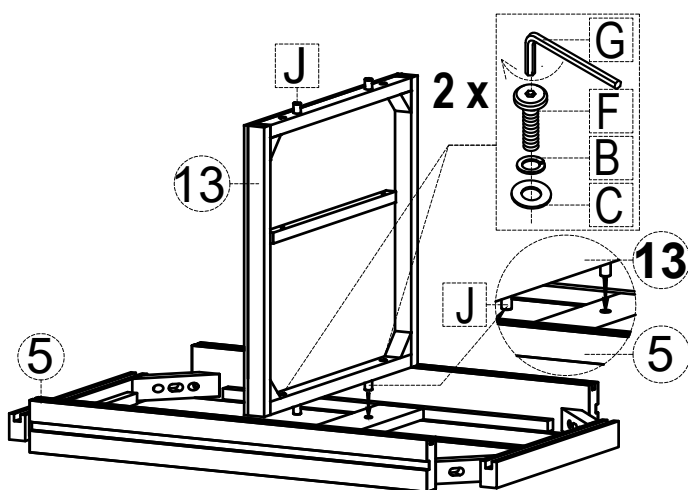

Step 3

Carefully lay the Shelf Unit on the side and attach a Right Side Leg and a Left Side Leg to the top corners using a Bolt (E), a Lock Washer (B) and a flat Washer (C).

Note that the groove in the leg will be on the inside of the unit. Repeat for the other side. Make sure all bolts are securely tightened.

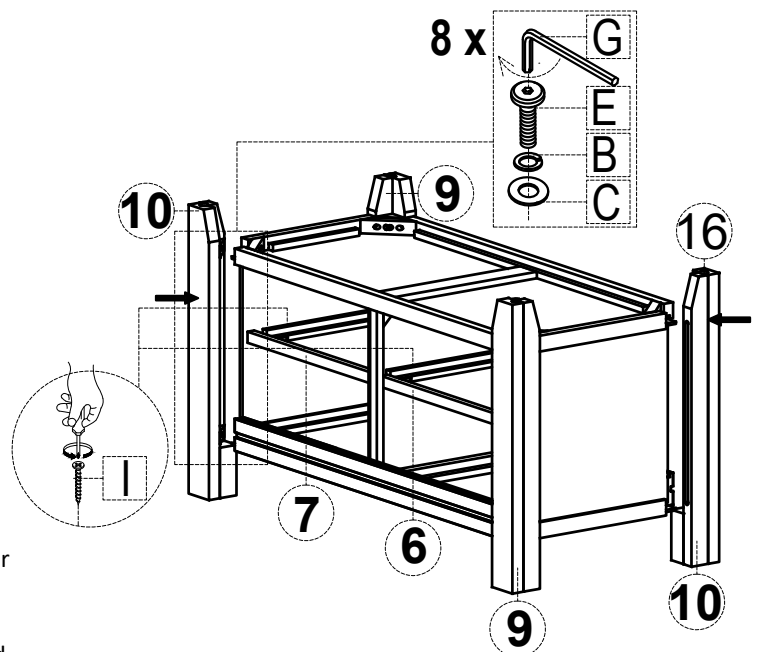
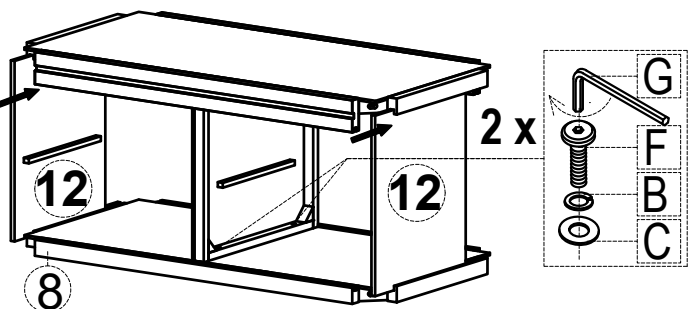

Step 4

Attach the shelves into place with the wood screws (I). Note there are two different size shelves.

Step 5

Place the Table Base upright and position the doors in place. Note that the rollers go into the base track and the guide pins lock into the top track.

Attach the Leg Extensions (for counter height table) using the Long Bolt (D), Lock Washer (B) and Flat Washer (C).

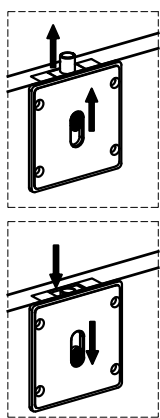

TO REACTIVATE DOOR PIN, PRESS THE BUTTON WHEN IN THE BOTTOM POSITION

TO RELEASE DOOR PIN, MOVE THE BUTTON TO THE BOTTOM POSITION

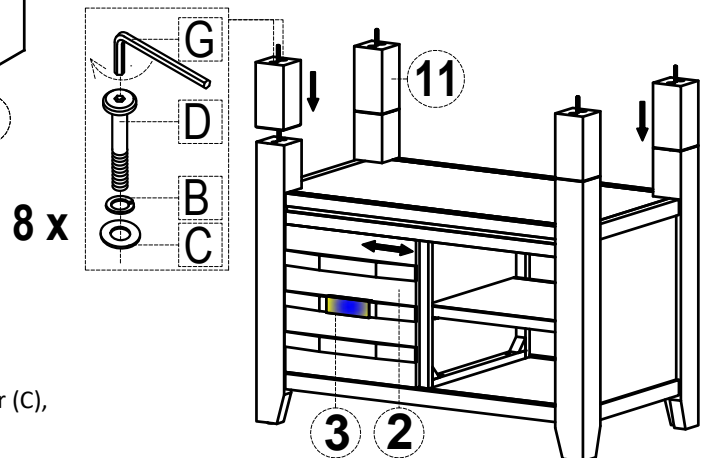
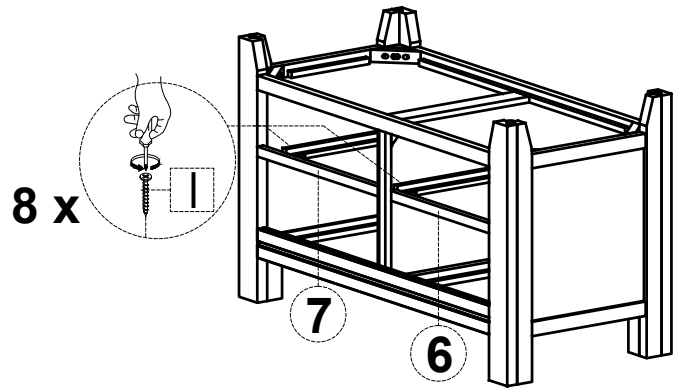
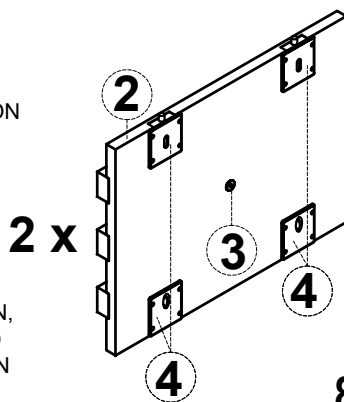

Step 6

Place the table top on top of the legs and attach with a Flat Washer (C), Lock Washer (B) and a nut (A).

Tighten with the wrench (H) provided.

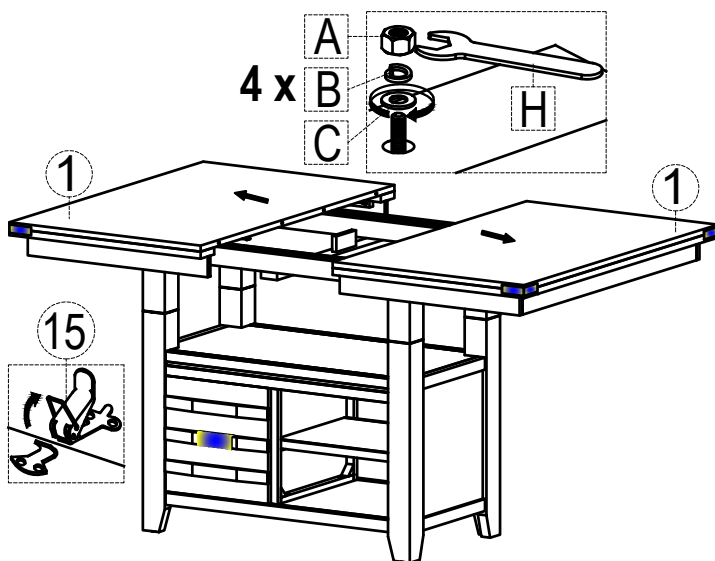

FINISH

