

Parts key				Hardware kit #1851-72P01			
No	Code	Qty	Description	No	Description		Qty
1	1851-72P24	1 pc	Table Top	A	Hex nut M8		4 pcs
2	1851-72P07	4 pcs	Sliding Door	B	Lock washer	Ø8	28 pcs
3	1851P04	4 pcs	Pull w/Screws	C	Flat washer	Ø8 x 16mm	28 pcs
4	1851P07S	8 sets	Sliding Wheel & Lock w/Screws - 2 pcs	D	Long bolt-Attaching Leg Extension	5/6" x 180mm	8 pcs
5	1851-72P08T	1 pc	Storage Box Top Panel	E	Medium bolt Attaching Leg	M6 x 60mm	8 pcs
6	1851-72P08	1 pc	Storage Box Shelf	F	Short bolt Attaching Top/Bottom Panel	M6 x 30mm	8 pcs
7	1851-72P08B	1 pc	Storage Box Bottom Panel	G	Allen key	K4	1 pc
8	1851-72P02L	2 pcs	Left Facing Leg	H	Key wrench	13	1 pc
9	1851-72P02R	2 pcs	Right Facing Leg	I	Wooden Screw	Ø4 x 25mm	6 pcs
10	1851-72P02E	2 pcs	Extensions Leg	J	Wooden Dowel	Ø10 x 20mm	8 pcs
11	1851-72P08S	2 pcs	Storage Box Side Panel				
12	1851-72P08V	2 pcs	Storage Box Vertical Panel				
13	1851-72P13	2 sets	Extension Mechanism				
14	1851-72P13L	4 sets	Extension Lock				
15	1851P01F	4 pcs	Floor Glide				
16	1851-72P36	1 pc	Leaf Support				

Step 1

Lay the top of the Storage Box upside down on a clean padded surface to prevent scratching. Insert the Wood Dowels (J) into the Vertical Panel ends.

Attach the two Storage Box Vertical Panels to the top shelf using a Short Bolt (F), a Lock Washer (B) and a Flat Washer (C) using the Allen key provided.

Attach the Middle Shelf to the Vertical Panels using the four Wood Screws (I).

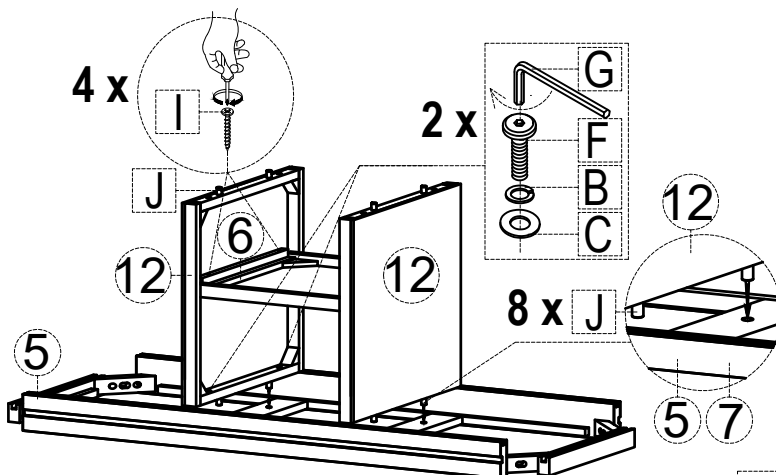

Step 3

Carefully lay the Shelf Unit on the side and attach a Right Side Leg and a Left Side Leg to the top corners using a Bolt (E), a Lock Washer (B) and a flat Washer (C). Diagram 4 Note that the groove in the leg will be on the inside of the unit.

Repeat for the other side. Make sure all bolts are securely tightened.

Step 2

Attach the bottom of the Storage Box to the Vertical Partitions using a Short Bolt (F), a Lock Washer (B) and a Flat Washer (C). Slide the Side Panels into the grooves on the Top and Bottom Panels as show in the diagram.

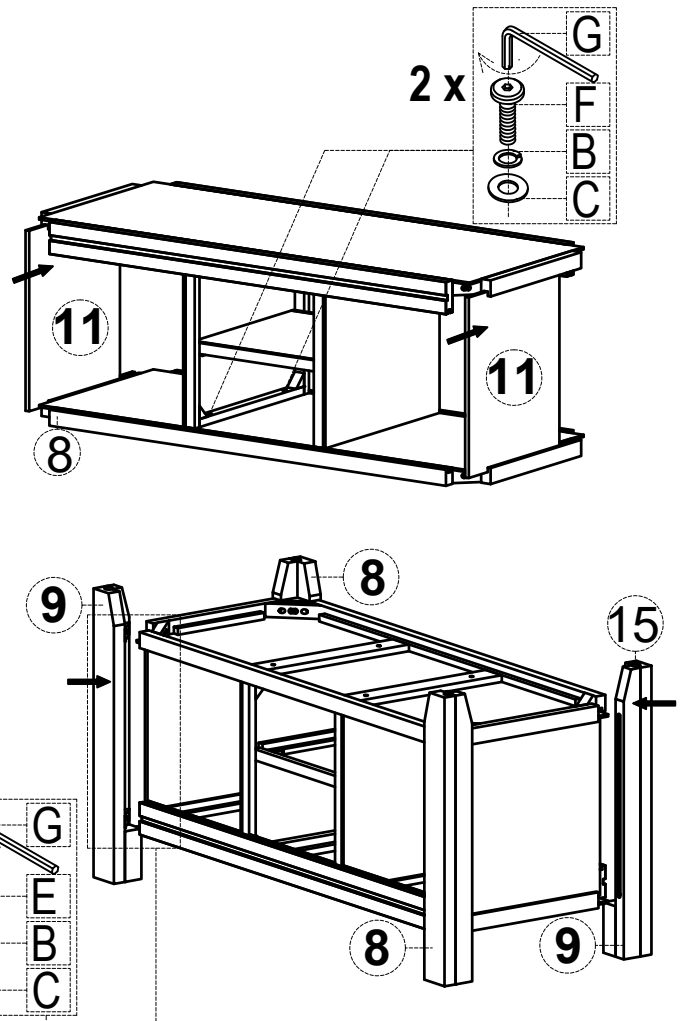

Step 4

Place the Table Base upright and position the doors in place. Note that the rollers go into the base track and the guide pins lock into the top track.

Attach the Leg Extensions (for counter height table) using the Long Bolt (D), Lock Washer (B) and Flat Washer (C).

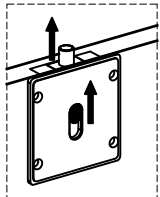

TO REACTIVATE DOOR PIN, PRESS THE BUTTON WHEN IN THE BOTTOM POSITION

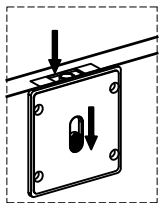

TO RELEASE DOOR PIN, MOVE THE BUTTON TO THE BOTTOM POSITION

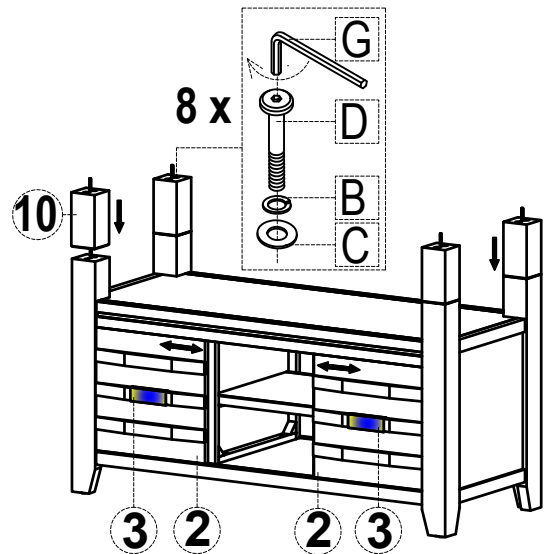
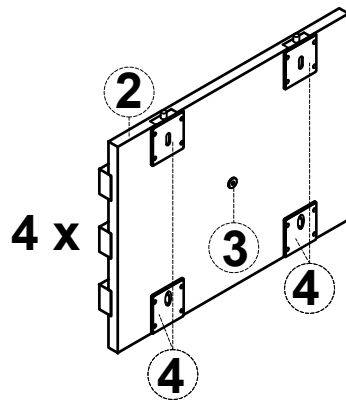

Step 5

Attach the Leaf Support to the Extension Mechanism using two Wood Screws (I) into the predrilled holes in the Extension Mechanism.

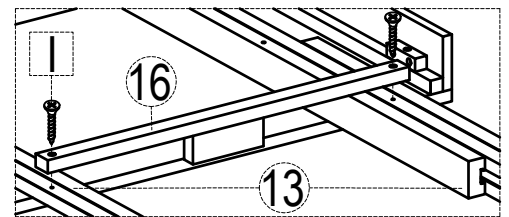

Step 6

Place the table top on top of the legs and attach with a Flat Washer (C), Lock Washer (B) and a nut (A).

Tighten with the wrench (H) provided.

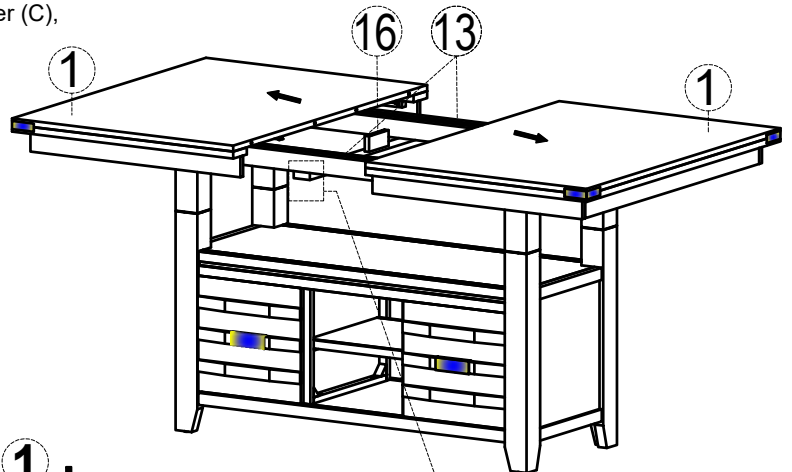
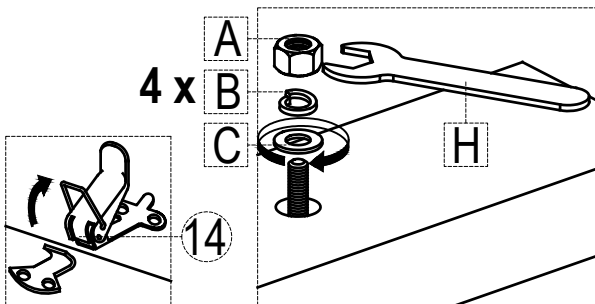

FINISH

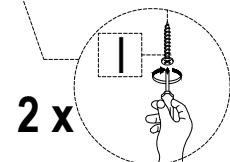
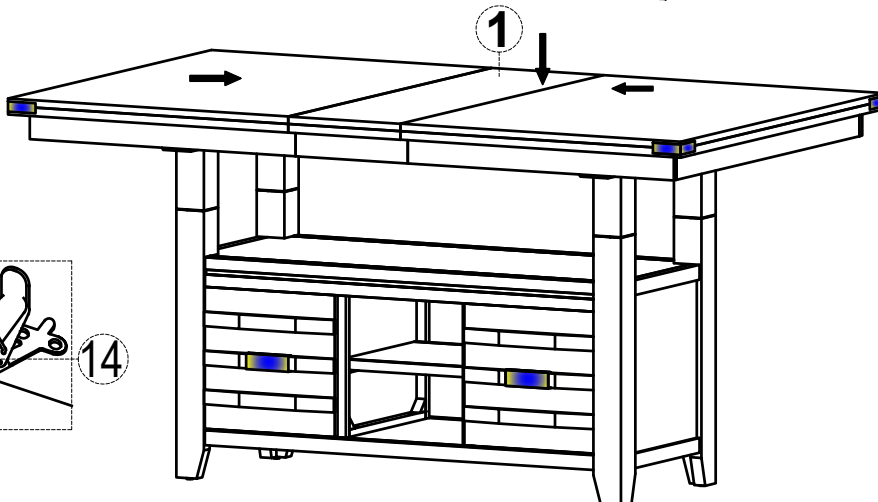

2 x