

### Table Hardware Kit (1846PO1)

Ltr	Qty	Description
A	8 pcs	Flat Washer
B	8 pcs	Lock Washer
C	8 pcs	Nut Ø5/16"
D	1 pc	Key Wrench

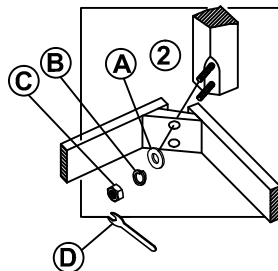
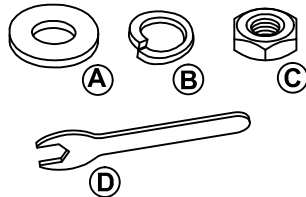

**Detail A**

### Table Parts Key

No	Code	Qty	Description
1	1846P01FT	4 pcs.	Table Floor Glide
2	1846P02	4 pcs.	Table Leg
3	1846P24	1 pc.	Table top

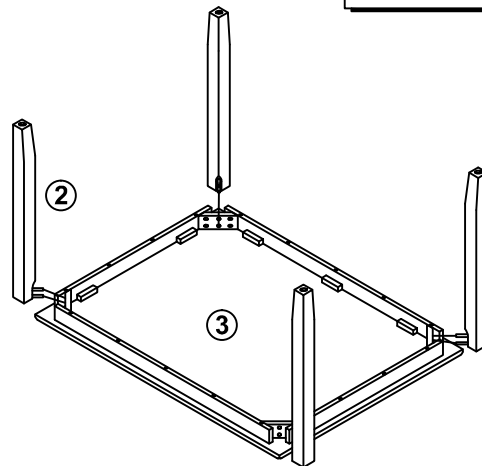

### STEP 1

- Carefully lay table top upside down on a smooth flat surface to prevent scratches.
- Affix a leg to each corner of the table top as shown in Detail A using a flat washer, lock washer and nut.
- Once all legs are in place, fully tighten the nuts

### Chair Hardware Kit (1846P46)

Ltr	Qty	Description
A	22 pcs.	Flat Washer
B	22 pcs.	Lock Washer
C	8 pcs.	Nut Ø5/16"
D	2 pcs.	Key Wrench
E	8 pcs.	Long KD. Bolt Øm6x 75mm.
F	6 pcs.	Short KD. Bolt Øm6x 40mm.
G	2 pcs.	Allen Wrench
H	12 pcs.	Screw Ø4 x 38mm

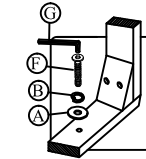
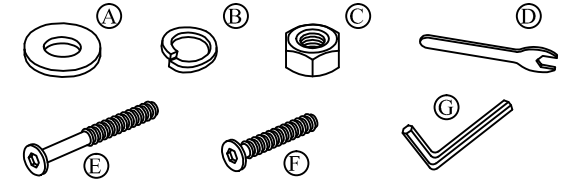

**Detail A**

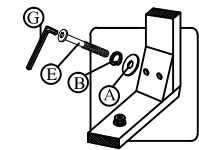

**Detail B**

### STEP 1

- Carefully lay chair back flat on a smooth flat surface to prevent scratches.
- Affix the complete seat to chair back, as shown in Detail A, using a flat washer, lock washer and short KD bolt.
- Secure complete seat to chair back corners, as shown in Detail B, using a flat washer, lock washer and long KD bolt.

### Chair Parts Key

No	Code	Qty	Description
5	1806P01F	8 pcs.	Chair/Bench Floor Glide
6	1846-BS395KDP40	2 pcs.	Chair Back
7	1846-BS395KDP41	2 pcs.	Complete Seat
8	1846-BS395KDP42	2 pcs.	Right Facing Front Leg
9	1846-BS395KDP43	2 pcs.	Left Facing Front Leg
10	1846-BS395KDP44	2 pcs.	Right Facing Side Stretcher
11	1846-BS395KDP45	2 pcs.	Left Facing Side Stretcher
12	1846-BS395KDP49	2 pcs.	Front Stretcher

\* Quantities noted are for a total of two chairs.

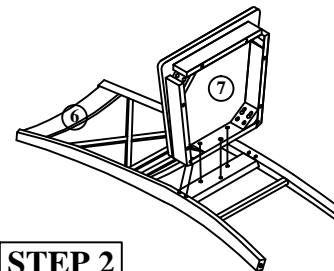

**Detail C**

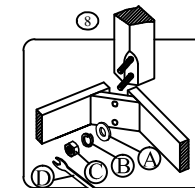

### DETAIL D

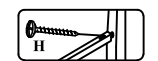

### STEP 2

- Carefully turn Chair upside down and attach each Leg to the front corners of the Complete Seat. Noting Right and Left Side Leg.
- Place Flat Washer, Lock Washer and Nut on for each bolt, using provided Key Wrench.
- Do not fully tighten the Nuts at this stage until all the parts are in position (See Detail C).
- Insert 2 Side Stretchers between the Front Legs and Back Legs (Noting Right and Left Side Stretcher), and insert the Front Stretcher between the Front Legs; fasten with Wood Screw using phillip-head screwdriver. (not provided). (See Detail D)
- Be sure to tighten all screws and nuts prior to using Chair.

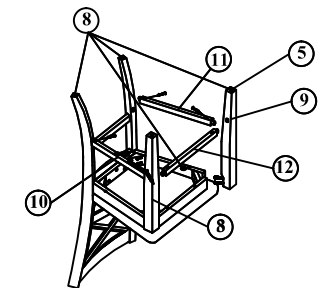

### Bench Hardware Kit (1846P46B)

Ltr	Qty	Description
A	8 pcs	Flat Washer
B	8 pcs	Lock Washer
C	8 pcs	Nut Ø5/16"
D	1 pc	Key Wrench
E	6 pcs	Screw Ø4 x 38mm

### Bench Parts Key

No	Code	Qty	Description
1	1846P42B	2 pcs.	Right Facing Bench Leg
2	1846P43B	2 pcs.	Left Facing Bench Leg
3	1846P41B	1 pc.	Bench Seat
4	1846P44BS	1 pc.	Short Bench Stretcher
5	1846P44BL	2 pcs.	Long Bench Stretcher
6	1846P01F	4 pcs.	Chair/Bench Floor Glide

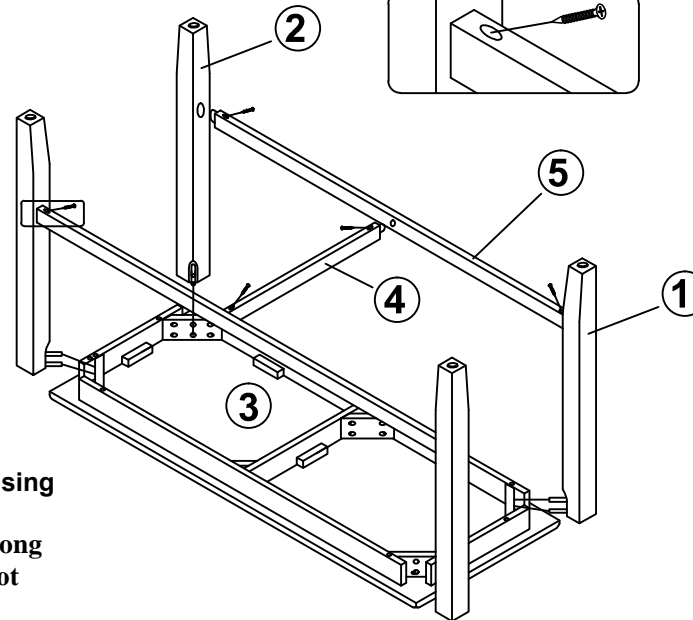
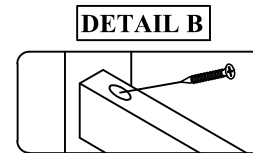
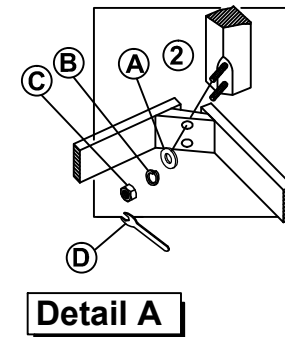
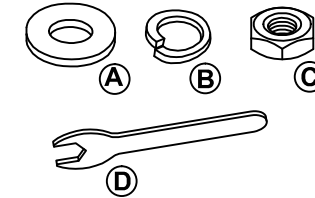

### STEP 1

- Carefully lay bench seat upside down on a smooth flat surface to prevent scratches.
- Affix a leg to each corner of the bench seat as shown in Detail A using a flat washer , lock washer and nut .
- Insert 2 Long Stretchers then insert the Short Stretcher between 2 Long Stretcher; fasten with Wood Screw using phillip-head screwdriver. (not provided).(See Detail B)
- Once all legs are in place, fully tighten the nuts