

Thank you for purchasing this quality product. Be sure to check all packing material carefully for small parts that may have come loose inside the carton during shipment.

Key Parts			
No	Code	Q'Ty	Description
1	1841-BS420KDP40	1 pc	Chair Back
2	1841-BS420KDP41	1 pc	Complete Seat
3	1841-BS420KDP42	1 pc	Right Facing Front Leg
4	1841-BS420KDP43	1 pc	Left Facing Front Leg
5	1841-BS420KDP44	1 pc	Right Facing Stretcher
6	1841-BS420KDP45	1 pc	Left Facing Stretcher
7	1841-BS420KDP49	1 pc	Front Stretcher
8	1841-P01F	4 pcs	Floor glide

Hardware kit 1841-BS420KDP46			
No		Description	Q'Ty
A		Hexa Nut Ø8	4 pcs
B		Lock Washer Ø8.5	11 pcs
C		Flat Washer Ø8.5	11 pcs
D		Long Bolt Ø7.8 x 80mm	4 pcs
E		Short Bolt Ø7.8 x 38mm	3 pcs
F		Allen Key	1 pc
G		Key Wrench	1 pc
H		Screw Ø4 x 40mm	6 pcs

STEP 1:

- Carefully lay Chair Back flat on a smooth flat surface to prevent scratches.
- Attach Complete Seat to Chair Back by inserting a Flat Washer (C), Lock Washer (B) with Short Bolt (E) into each of the hole on the back rail of the seat, and Long Bolt (D) into each of 2 holes in the Complete Seat corners. (See Detail A & B).
- Tighten screws with provided Allen Key (F) by turning clockwise until secure

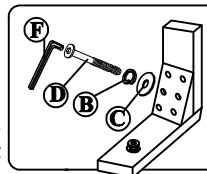

DETAIL B

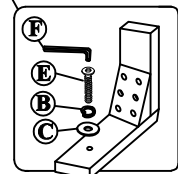
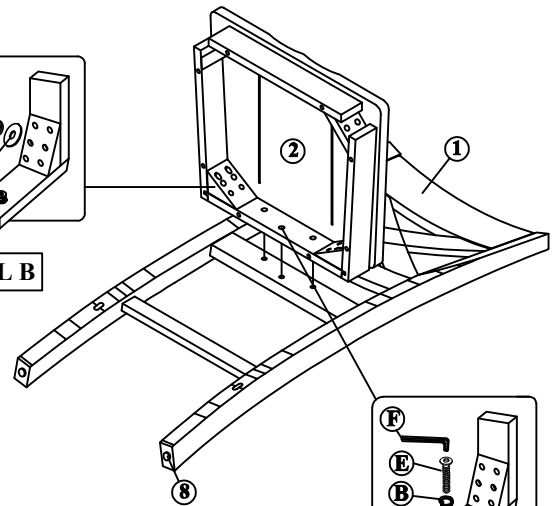

DETAIL A

DETAIL D

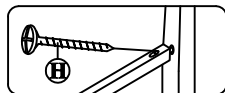

STEP 2:

- Carefully turn Chair upside down and attach each Leg to the front corners of the Complete Seat.
- Place Flat Washer (C), Lock Washer (B) and Nut (A) on for each bolt, using provided Key Wrench (G).
- Do not fully tighten the Nuts at this stage until all the parts are in position (See Detail C).
- Insert 2 Side Stretchers between the Front Legs, fasten with Wood Screw using phillip-head screwdriver. (not provided). (See Detail D)
- Be sure to tighten all screws and nuts prior to using Chair.

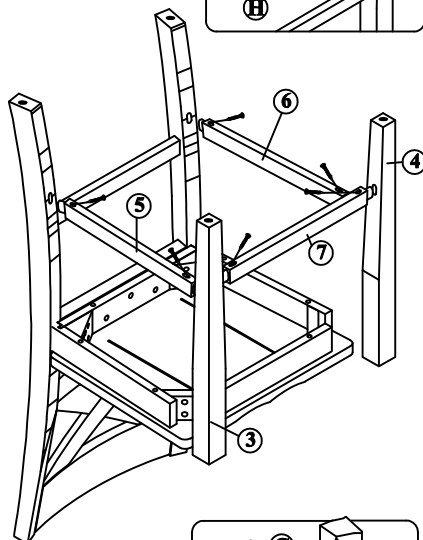

DETAIL C

