







Thank you for purchasing this quality product. Be sure to check all packing material carefully for small parts that may have come loose inside the carton during shipment.

Key Parts			
No	Code	Q'Ty	Description
1	1841-395KDP40	1 pc	Chair Back
2	1841-395KDP41	1 pc	Complete Seat
3	1841-395KDP42	2 pc	Front Leg
4	1841-P01F	4 pcs	Floor glide

Hardware kit 1841-395KDP46			
No		Description	Q'Ty
A		Hexa Nut Ø7.8	4 pcs
B		Lock Washer Ø8.5	11 pcs
C		Flat Washer Ø8.5	11 pcs
D		Long Bolt Ø7.8 x 80mm	4 pcs
E		Short Bolt Ø7.8 x 38mm	3 pcs
F		Allen Key	1 pc
G		Key Wrench	1 pc

STEP 1

- Carefully lay Chair Back flat on a smooth flat surface to prevent scratches.
- Affix Complete Seat to Chair Back by inserting a Flat Washer, Lock Washer and Short K.D. Screw into each of the hole on the back of the seat. Tighten screws with provided Allen Key by turning clockwise until secure. (See Detail A).
- Insert a Flat Washer, Lock Washer and Long K.D. Screw into each of 2 holes in the Complete Seat corners. Tighten screws with provided Key Wrench. (See Detail B).

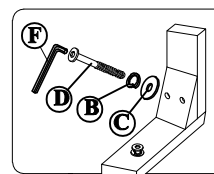
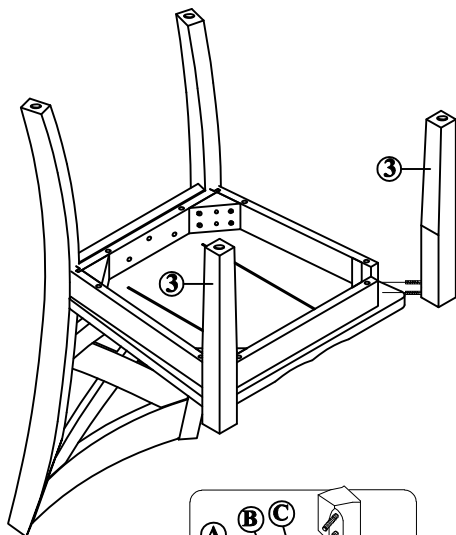

DETAIL B

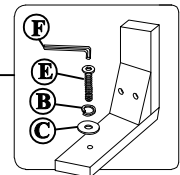
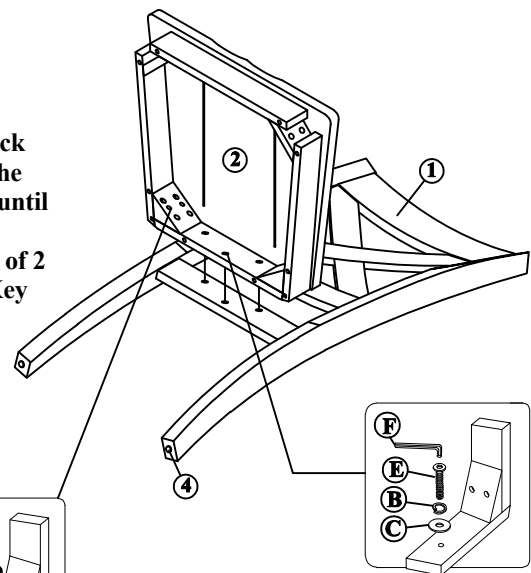

DETAIL A

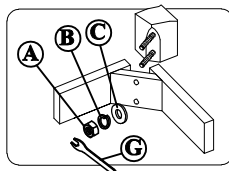

DETAIL C

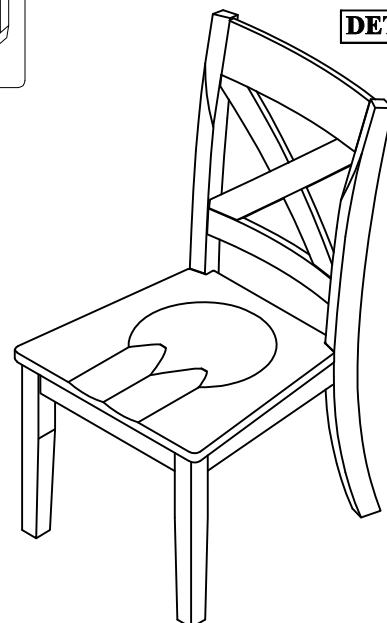

STEP 2

- Carefully turn chair upside down and affix each Leg to the front corners of the Complete Seat. Place Flat Washer, Lock Washer and Nut on each leg bolt, tightening the Nut on each Leg using provided Key Wrench. (See Detail C).
- Be sure to level the chair prior to tightening all the nuts/screws