

Hardware Kit (1839 - BS42KDP46)		
Bench Hardware		
Ltr	Qty	Description
A	8 pcs	Flat Washer
B	8 pcs	Lock Washer
C	8 pcs	Nut Øm8
D	1 pc	Key Wrench
E	6 pcs	Screw Ø4 x 38mm

Bench Parts Key			
No	Code	Qty	Description
1	1839 - BS42KDP42	2 pcs.	Right Facing Front Leg
2	1839 - BS42KDP43	2 pcs.	Left Facing Front Leg
3	1839 - BS42KDP41	1 pc.	Bench Seat
4	1839 - BS42KDP44BS	1 pc.	Short Bench Stretcher
5	1839 - BS42KDP44BL	2 pcs.	Long Bench Stretcher
6	1839 - BS42KDP01F	4 pcs.	Bench/Stool Floor Glide

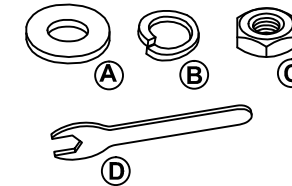

STEP 1

- Carefully lay bench seat upside down on a smooth flat surface to prevent scratches.
- Affix a leg to each corner of the bench seat as shown in Detail A using a flat washer, lock washer and nut. Do not fully tighten
- Insert 2 Long Stretchers then insert the Short Stretcher between the Long Stretchers; fasten with Wood Screw using phillip-head screwdriver. (not provided).(See Detail B)
- Once all legs/ stretchers are in place, fully tighten the nuts.

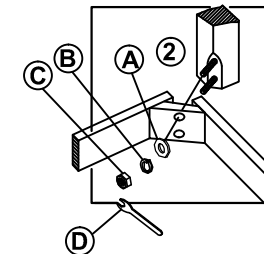
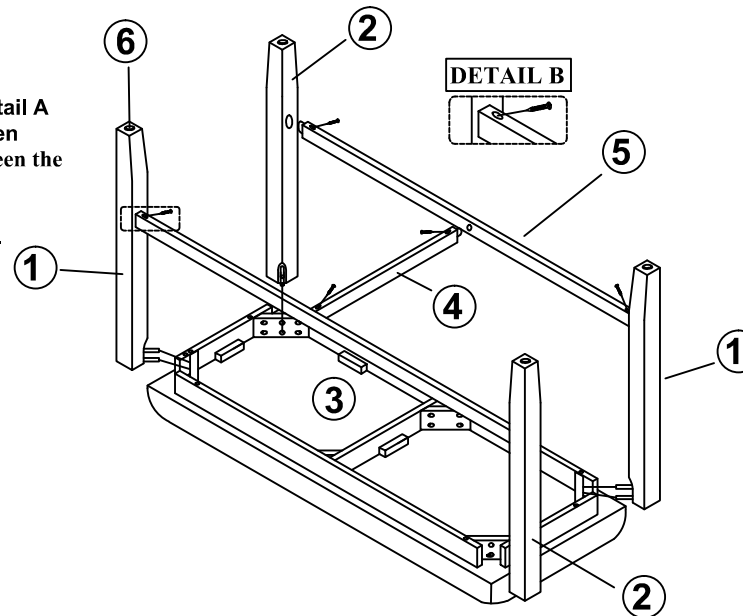

Detail A

DETAIL B