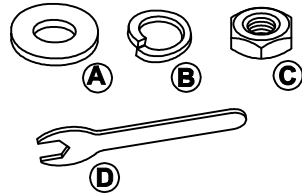

Table Hardware Kit (1836PO1)



| Ltr | Qty | Description |
|-----|-------|-------------|
| A | 8 pcs | Flat Washer |
| B | 8 pcs | Lock Washer |
| C | 8 pcs | Nut Ø5/16" |
| D | 1 pc | Key Wrench |

Table Parts Key

| No | Code | Qty | Description |
|----|-----------|--------|-------------------|
| 1 | 1836P01FT | 4 pcs. | Table Floor Glide |
| 2 | | 4 pcs. | Table Leg |
| 3 | | 1 pc. | Table top |

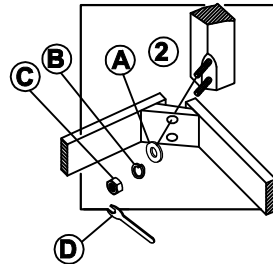

Detail A

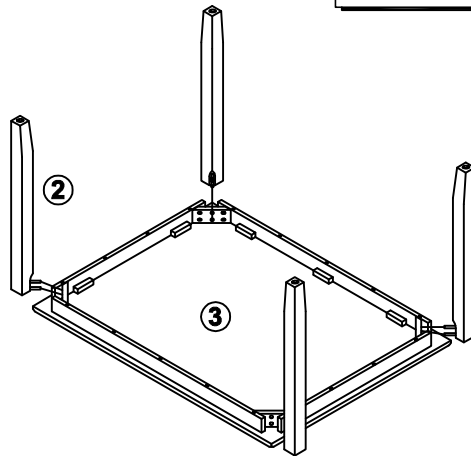

STEP 1

- Carefully lay table top upside down on a smooth flat surface to prevent scratches.
- Affix a leg to each corner of the table top as shown in Detail A using a flat washer, lock washer and nut.
- Once all legs are in place, fully tighten the nuts

Chair Hardware Kit (1836P46)

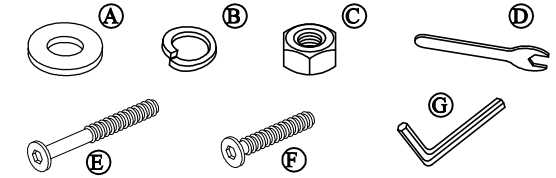

| Ltr | Qty | Description |
|-----|---------|-----------------------------|
| A | 22 pcs. | Flat Washer |
| B | 22 pcs. | Lock Washer |
| C | 8 pcs. | Nut Ø5/16" |
| D | 2 pcs. | Key Wrench |
| E | 8 pcs. | Long KD. Bolt Ø1/4"x 3". |
| F | 6 pcs. | Short KD. Bolt Ø1/4"x 1.5". |
| G | 2 pcs. | Allen Wrench |
| H | 12 pcs. | Screw Ø1/6" x 1-1/2". |

Chair Parts Key

| No | Code | Qty | Description |
|----|----------|--------|-----------------------------|
| 5 | 1836P01F | 8 pcs. | Chair/Bench Floor Glide |
| 6 | | 2 pcs. | Chair Back |
| 7 | 1836P41 | 2 pcs. | Complete Seat |
| 8 | 1836P42 | 2 pcs. | Right Facing Front Leg |
| 9 | 1836P43 | 2 pcs. | Left Facing Front Leg |
| 10 | 1836P44 | 2 pcs. | Right Facing Side Stretcher |
| 11 | 1836P45 | 2 pcs. | Left Facing Side Stretcher |
| 12 | 1836P49 | 2 pcs. | Front Stretcher |

STEP 1

- Carefully lay chair back flat on a smooth flat surface to prevent scratches.
- Affix the complete seat to chair back, as shown in Detail A, using a flat washer, lock washer and short KD bolt.
- Secure complete seat to chair back corners, as shown in Detail B, using a flat washer, lock washer and long KD bolt. -- Tighten screws with provided Allen Wrench.

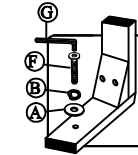

Detail A

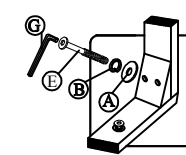

Detail B

* Quantities noted are for a total of two chairs.

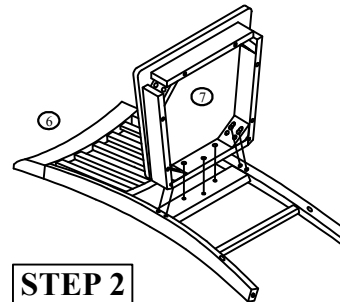

Detail C

STEP 2

- Carefully turn Chair upside down and attach each Leg to the front corners of the Complete Seat. Noting Right and Left Side Leg.
- Place Flat Washer, Lock Washer and Nut on for each bolt, using provided Key Wrench.
- Do not fully tighten the Nuts at this stage until all the parts are in position (See Detail C).
- Insert 2 Side Stretchers between the Front Legs and Back Legs (Noting Right and Left Side Stretcher), and insert the Front Stretcher between the Front Legs; fasten with Wood Screw using phillip-head screwdriver. (not provided). (See Detail D)
- Be sure to tighten all screws and nuts prior to using Chair.

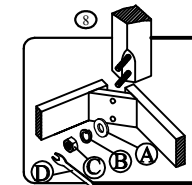

DETAIL D

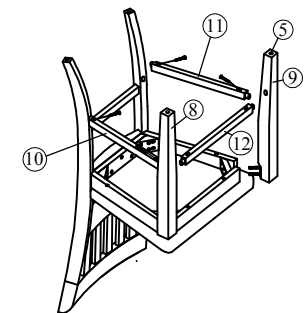

Bench Hardware Kit (1836P46B)

| Ltr | Qty | Description |
|-----|-------|----------------------|
| A | 8 pcs | Flat Washer |
| B | 8 pcs | Lock Washer |
| C | 8 pcs | Nut Ø5/16" |
| D | 1 pc | Key Wrench |
| E | 6 pcs | Screw Ø1/6" x 1-1/2" |

Bench Parts Key

| No | Code | Qty | Description |
|----|-----------|--------|-------------------------|
| 1 | 1836P42B | 2 pcs. | Right Facing Bench Leg |
| 2 | 1836P43B | 2 pcs. | Left Facing Bench Leg |
| 3 | | 1 pc. | Bench Seat |
| 4 | 1836P44BS | 1 pc. | Short Bench Stretcher |
| 5 | | 2 pcs. | Long Bench Stretcher |
| 6 | 1836P01F | 4 pcs. | Chair/Bench Floor Glide |

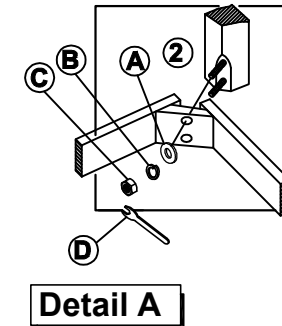
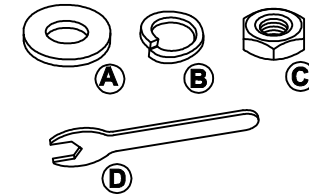

DETAIL B

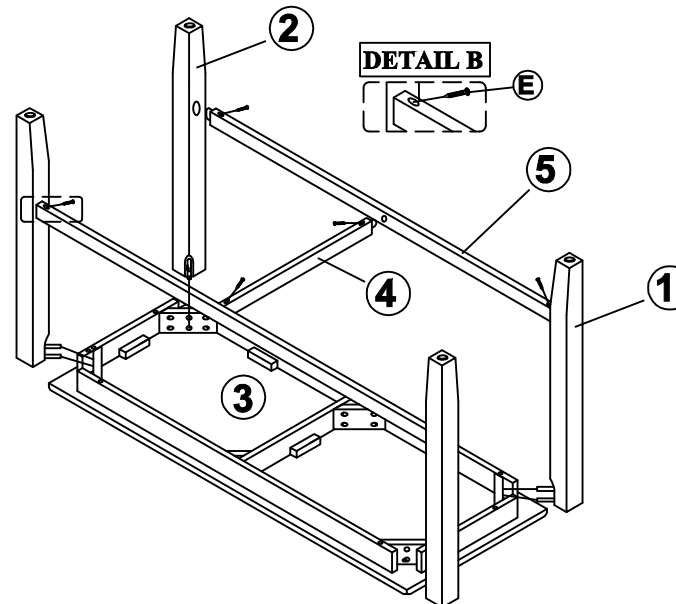

STEP 1

- Carefully lay bench seat upside down on a smooth flat surface to prevent scratches.
- Affix a leg to each corner of the bench seat as shown in Detail A using a flat washer , lock washer and nut .
- Insert 2 Long Stretchers then insert the Short Stretcher between 2 Long Stretcher; fasten with Wood Screw using phillip-head screwdriver. (not provided).(See Detail B)
- Once all legs are in place, fully tighten the nuts