

Table Hardware Kit (1835PO1)

Ltr	Qty	Description
A	8 pcs	Flat Washer
B	8 pcs	Lock Washer
C	8 pcs	Nut Øm8
D	1 pc	Key Wrench

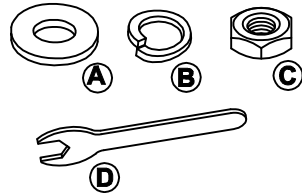
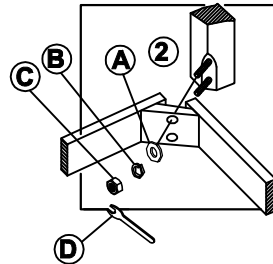
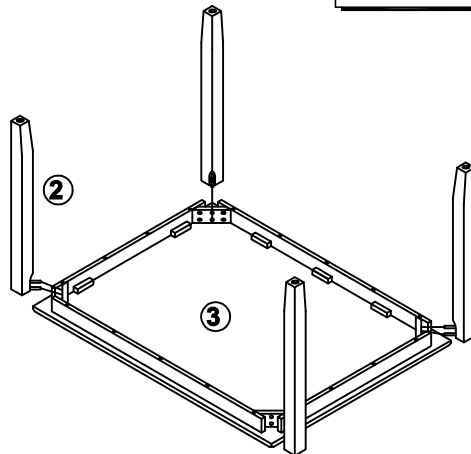

Table Parts Key

No	Code	Qty	Description
1	1835P01FT	4 pcs.	Table Floor Glide
2		4 pcs.	Leg
3		1 pc.	Table top



Detail A



STEP 1

- Carefully lay table top upside down on a smooth flat surface to prevent scratches.
- Affix a leg to each corner of the table top as shown in Detail A using a flat washer, lock washer and nut.
- Once all legs are in place, fully tighten the nuts

Chair Hardware Kit (1835P46)

Ltr	Qty	Description
A	22 pcs.	Flat Washer 5/16"
B	22 pcs.	Lock Washer 5/16"
C	8 pcs.	Nut 5/16"
D	1 pc.	Key Wrench
E	8 pcs.	Long KD. Bolt 1/4"x 3"
F	6 pcs.	Short KD. Bolt 1/4"x 1.5"
G	1 pc.	Allen Wrench

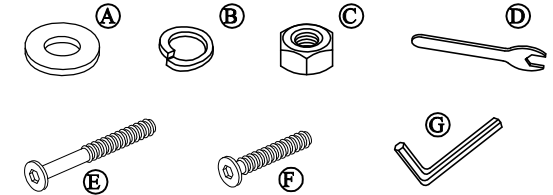

Chair Parts Key

No	Code	Qty	Description
5	1835P01F	8 pcs.	Chair/Bench Floor Glide
6		2 pcs.	Chair Back
7	1835P41	2 pcs.	Complete Seat
8	1835P42	4 pcs.	Front Chair Leg

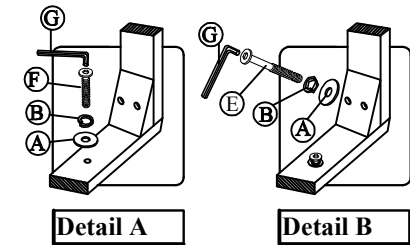

Detail A

Detail B

* Quantities noted are for a total of two chairs.

STEP 1

- Carefully lay chair back flat on a smooth flat surface to prevent scratches.
- Affix the complete seat to chair back, as shown in Detail A, using a flat washer, lock washer and short KD bolt.
- Secure complete seat to chair back corners, as shown in Detail B, using a flat washer, lock washer and long KD bolt. - - Tighten screws with provided Allen Wrench.

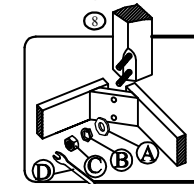
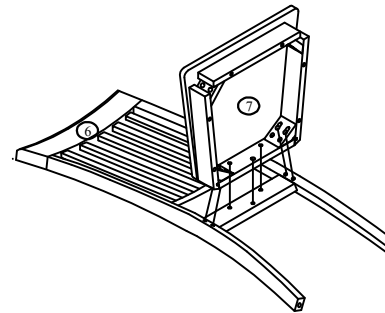

Detail C

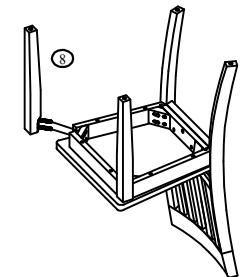

STEP 2

- Carefully turn chair upside down and affix each Leg to the front corner of the complete seat, as shown in Detail C, using a flat washer, lock washer, and nut.
- Turn chair upright and make sure it is level before fully tightening all bolts and nuts.
- Be sure to tighten all screws prior to using chair.

Bench Hardware Kit (1835P46B)

Ltr	Qty	Description
A	8 pcs	Flat Washer
B	8 pcs	Lock Washer
C	8 pcs	Nut Øm8
D	1 pc	Key Wrench

Bench Parts Key

No	Code	Qty	Description
1	1835P01F	4 pcs.	Stool/Bench Floor Glide
2	1835P42B	4 pcs.	Bench Leg
3		1 pc.	Bench Seat

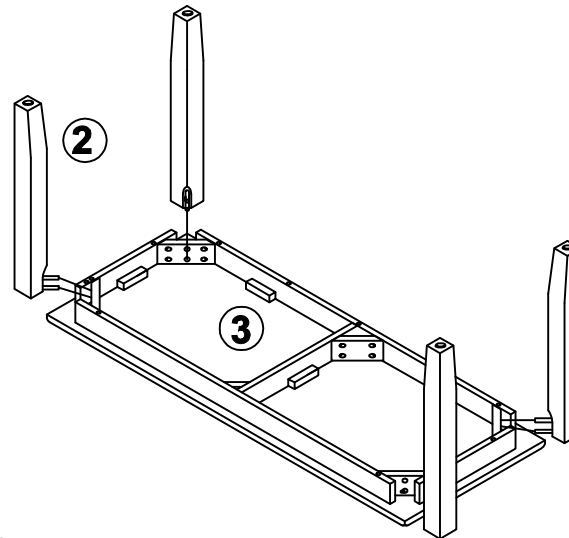
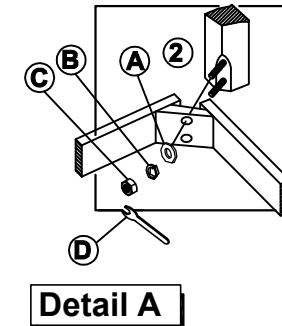
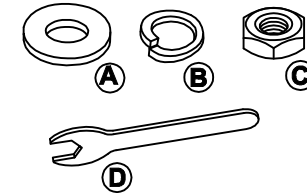

STEP 1

- Carefully lay bench seat upside down on a smooth flat surface to prevent scratches.
- Affix a leg to each corner of the bench seat as shown in Detail A using a flat washer , lock washer and nut .
- Once all legs are in place, fully tighten the nuts