

Thank you for purchasing this quality product. Be sure to check all packing material carefully for small parts that may have come loose inside the carton during shipment.

Hardware Kit (1816-BS175KDP46)		
Ltr	Qty	Description
A	8 pcs	Flat Washer
B	8 pcs	Lock Washer
C	8 pcs	Nut Ø5/16"
D	1 pc	Key Wrench
E	8 pcs	Screw Ø4 x 38mm

Parts Key			
No	Code	Qty	Description
1	1816-BS175KDP41	1 pc.	Complete Seat
2	1816-BS175KDP42	2 pcs.	Right Side Facing Leg
3	1816-BS175KDP43	2 pcs.	Left Side Facing Leg
4	1816-BS175KDP44S	2 pcs.	Small Side Stretcher
5	1816-BS175KDP49	2 pcs.	Front/ Back Stretcher
6	1816P01F	4 pcs.	Floor Glide

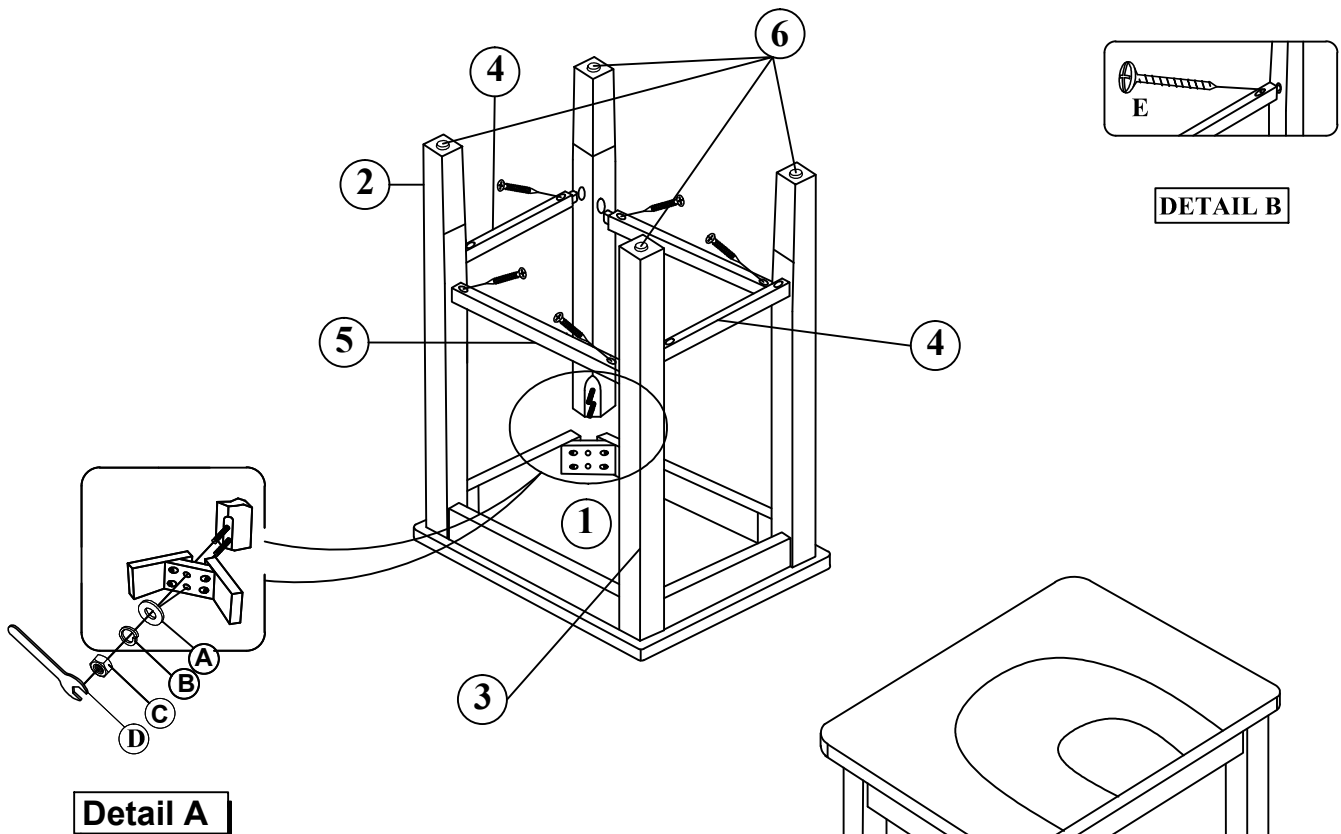

STEP 1

- Carefully lay the stool seat upside down on a smooth flat surface to prevent scratches.
- Affix a leg to each corner of the stool seat, noting the left side and right side, using a flat washer, lock washer and nut. (See Detail A) Do not fully tighten at this point.
- Insert the 2 Long Stretchers then insert the Short Stretchers between the legs; fasten with Wood Screw using phillip-head screwdriver. (not provided).(See Detail B)
- Once all Stretchers are in place, fully tighten the nuts