

ASSEMBLY INSTRUCTIONS & PARTS IDENTIFICATION MODEL # 1801-BS420KD COUNTER STOOL TELLURIDE GOLD

Thank you for purchasing this quality product. Be sure to check all packing material carefully for small parts that may have come loose inside the carton during shipment.

Parts key				Hardware kit #1801-BS420KDP46			
No	Code	Qty	Description	No	Description		Qty
1	1801-BS420KDP40	1 pc	Chair Back	A	Hexa Nut	Ø8	4 pcs
2	1801-BS420KDP41	1 pc	Complete Seat	B	Lock Washer	Ø8	11 pcs
3	1801-BS420KDP42	1 pc	Right Facing Front Leg	C	Flat Washer	Ø8	11 pcs
4	1801-BS420KDP43	1 pc	Left Facing Front Leg	D	Long Bolt	Ø7.8 x 80	4 pcs
5	1801-BS420KDP44	1 pc	Right Facing Side Stretcher	E	Short Bolt	Ø7.8 x 35	3 pcs
6	1801-BS420KDP45	1 pc	Left Facing Side Stretcher	F	Allen Key	K4	1 pc
7	1801-BS420KDP49	1 pc	Front Facing Side Stretcher	G	Key Wrench	12	1 pc
8	1801P01F	4 pcs	Floor glide	H	Screw	Ø4 x 40	6 pcs

FABRIC CARE INSTRUCTIONS REGULAR CARE FABRIC CONTENT

80% cotton and 20% linen - Cleaning code S

Professional cleaning recommended. Spot clean with mild water-free solvent or dry cleaning product. vacuum surface occasionally with an upholstery attachment.

STEP 1

- Carefully lay Chair Back flat on a smooth flat surface to prevent scratches.
- Attach Complete Seat to Chair Back by inserting a Flat Washer (C), Lock Washer (B) with Short Bolt (E) into each of the hole on the back rail of the seat. Attach the Long Bolt(D), Lock Washer (B) and Flat Washer (C) into each of 2 holes in the Complete Seat corners. (See Detail A & B).
- Tighten Bolts with provided Allen Key (F) by turning clockwise until secure.

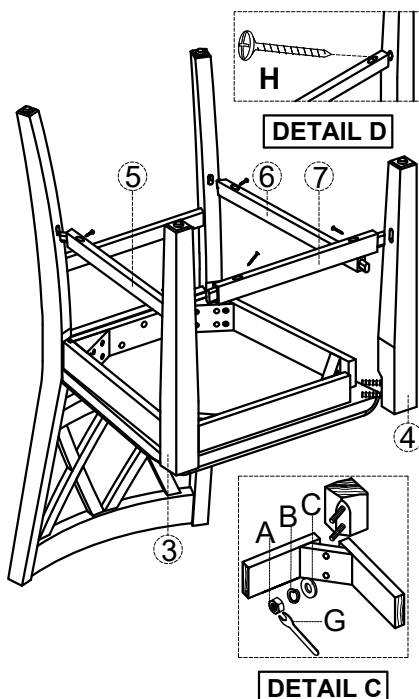
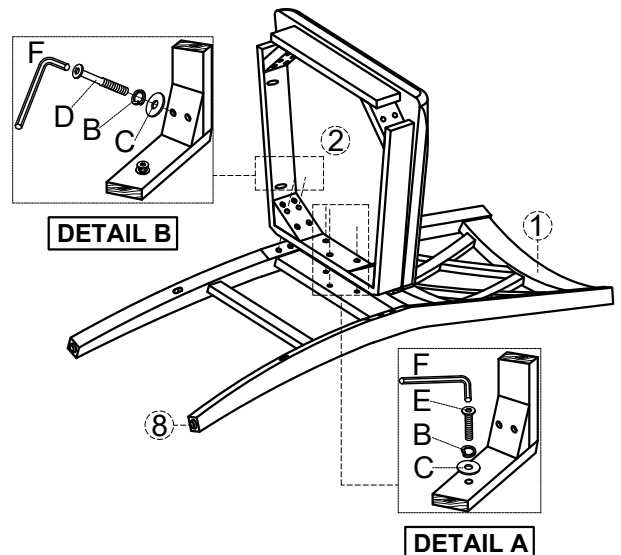

STEP 2

- Carefully turn chair upside down and attach each Front Leg to the front corners of the Complete Seat (Keeping in mind of the right side and left side leg) with a Flat Washer (C), Lock Washer (B) and Nut (A). (See detail C).
- Keep nut loose at this point.
- Insert right side stretcher and left side stretcher between the Front and Back Legs, then insert the Front Stretcher between the two Front Legs. (Make sure that the side stretchers are not at an angle as the front legs are on the wrong side). Fasten stretchers to legs with Screws (H) using a Screwdriver (not provide). Be sure to level the chair prior to tightening front leg nuts with wrench provided (G).

