

ASSEMBLY INSTRUCTIONS & PARTS IDENTIFICATION MODEL # 1801 - 42 COUNTER HEIGHT TRESTLE TABLE TELLURIDE GOLD

Thank you for purchasing this quality product. Be sure to check all packing material carefully for small parts that may have come loose inside the carton during shipment.

Parts key				Hardware kit #1801-42P01			
No	Code	Qty	Description	No	Description		Qty
1A	1801-42P13NL	2 pcs	Left Side Facing Extension Mechanism	A	Bolt	Ø7.8 x 50	6 pcs
1B	1801-42P13NR	2 pcs	Right Side Facing Extension Mechanism	B	Hex Nut	Ø8	8 pcs
2	1801-42P02L	2 pcs	Left Side Facing Leg	C	Semi lunar washer	Ø8 x 30	4 pcs
3	1801-42P02R	2 pcs	Right Side Facing Leg	D	Lock washer	Ø8	14 pcs
4	1801-42P11	1 pc	Center Connecting Stretcher	E	Big Flat washer	Ø10 x 22	8 pcs
5	1801-42P11S	2 pcs	Side Stretcher	F	Small Flat washer	Ø8 x 16	2 pcs
6	1801P01F	4 pcs	Floor Glide	G	Allen Key	K4	1 pc
				H	Wrench	12	1 pc

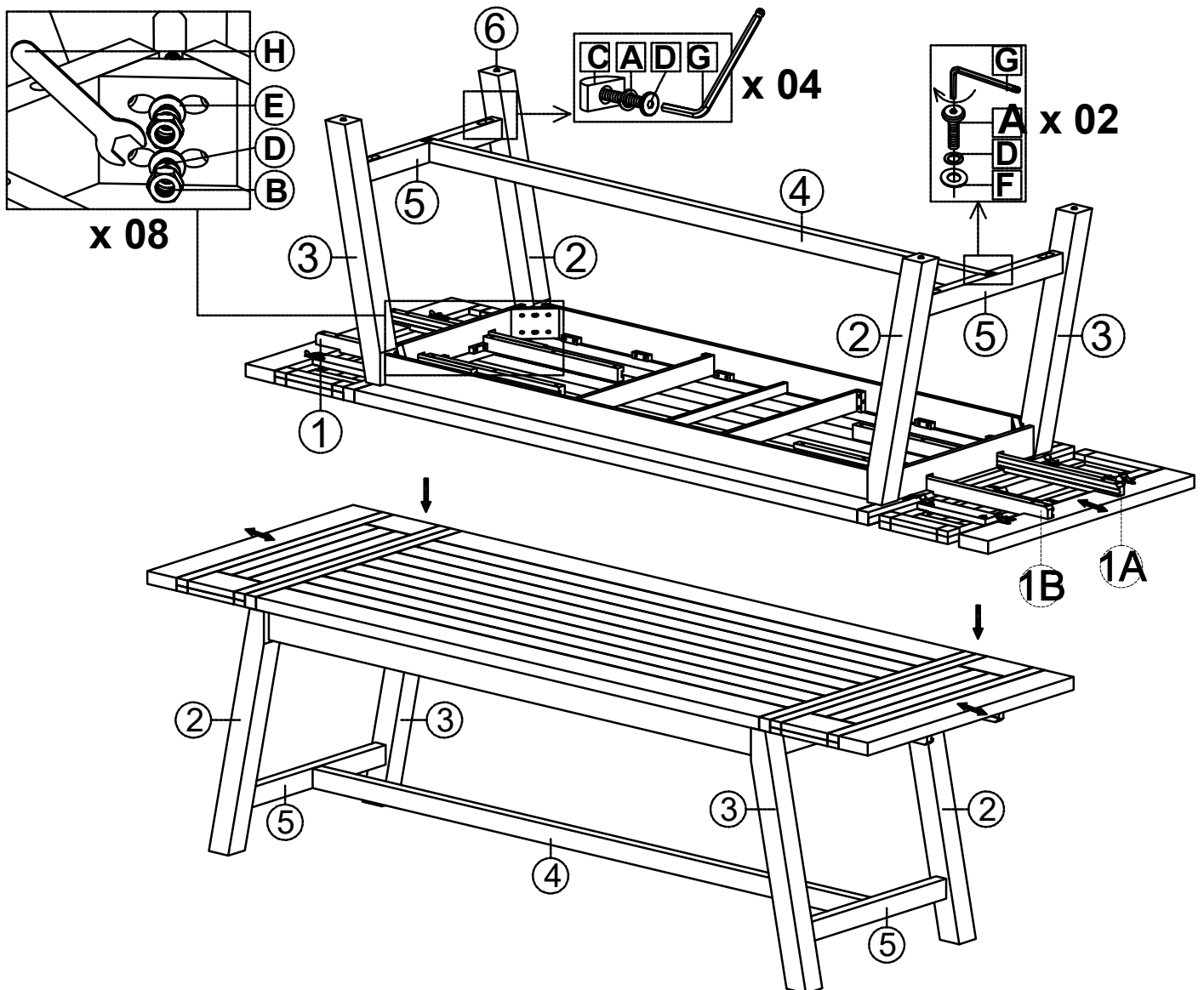

**ASSEMBLY INSTRUCTIONS &
PARTS IDENTIFICATION**
MODEL # 1801 - 42
COUNTER HEIGHT TRESTLE TABLE
TELLURIDE GOLD

Thank you for purchasing this quality product. Be sure to check all packing material carefully for small parts that may have come loose inside the carton during shipment.

The leaf out

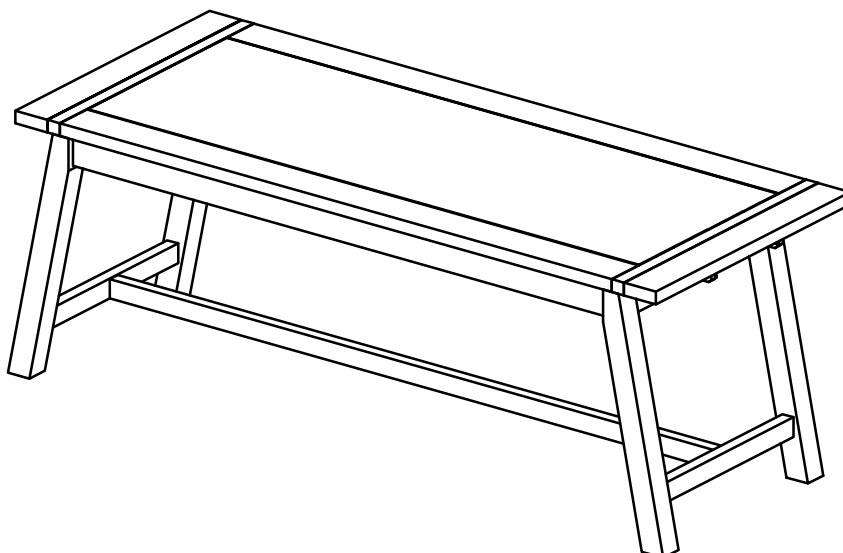
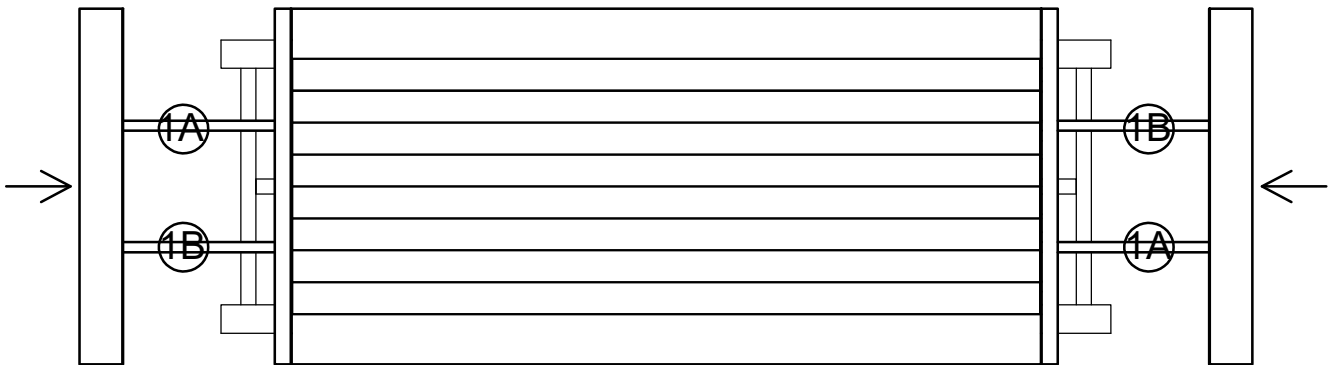
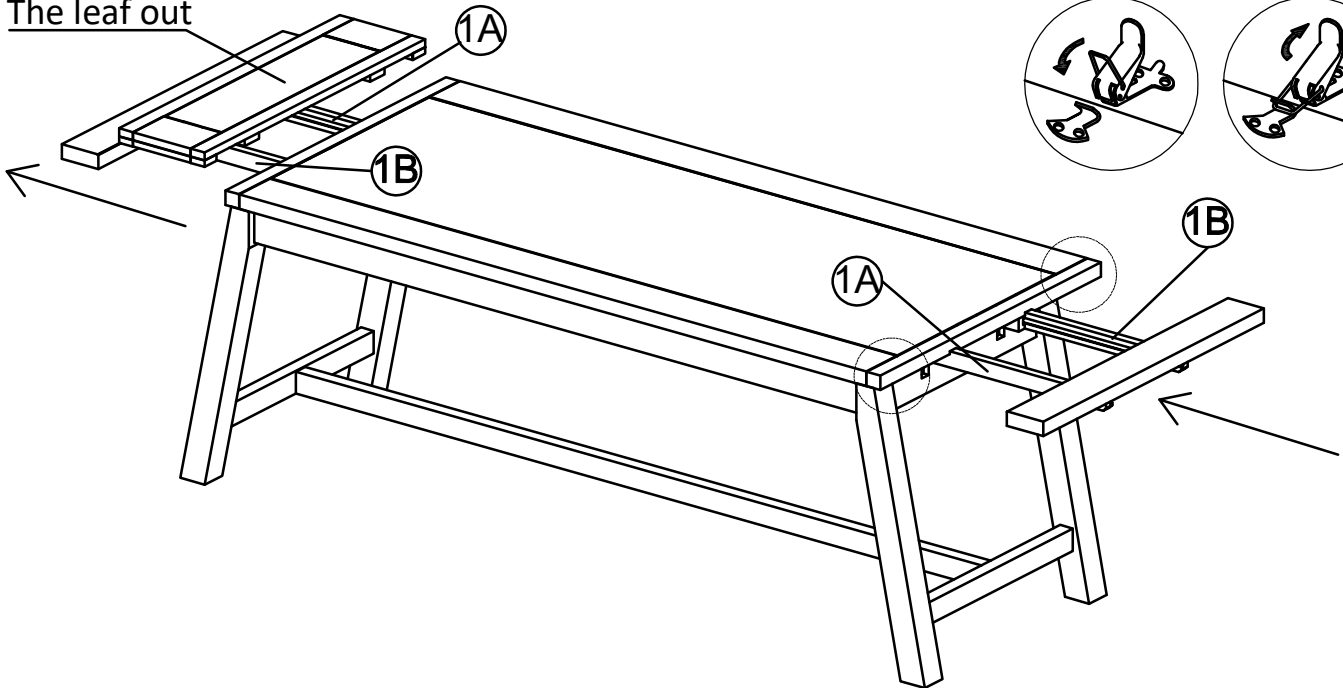

Thank you for purchasing this quality product. Be sure to check all packing material carefully for small parts that may have come loose inside the carton during shipment.

Parts key				Hardware kit #1801-401KDP46			
No	Code	Qty	Description	No	Description	Qty	
1	1801-401KDP40	1 pc	Chair Back	A	Hexa Nut	Ø8	4 pcs
2	1801-401KDP41	1 pc	Complete Seat	B	Lock Washer	Ø8	11 pcs
3	1801-401KDP42	2 pcs	Front Leg Floor	C	Flat Washer	Ø8	11 pcs
4	1801-401KDP01F	4 pcs	Glide	D	Long Bolt	Ø7.8 x 80	4 pcs
				E	Short Bolt	Ø7.8 x 35	3 pcs
				F	Allen Key	K4	1 pc
				G	Key Wrench	12	1 pc

**FABRIC CARE INSTRUCTIONS
REGULAR CARE
FABRIC CONTENT**

80% cotton and 20% linen - Cleaning code S
Professional cleaning recommended. Spot clean with mild water-free solvent or dry cleaning product. vacuum surface occasionally with an upholstery attachment.

STEP 1

- Carefully lay Chair Back flat on a smooth flat surface to prevent scratches.
- Attach Complete Seat to Chair Back by inserting a Flat Washer, Lock Washer and Short bolt into each of the hole on the back of the seat. Tighten screws with provided Allen Key by turning clockwise until secure. (See Detail A).
- Insert a Flat Washer, Lock Washer and Long screw into each of 2 holes in the Complete Seat corners. Tighten screws with provided Key Wrench. (See Detail B).

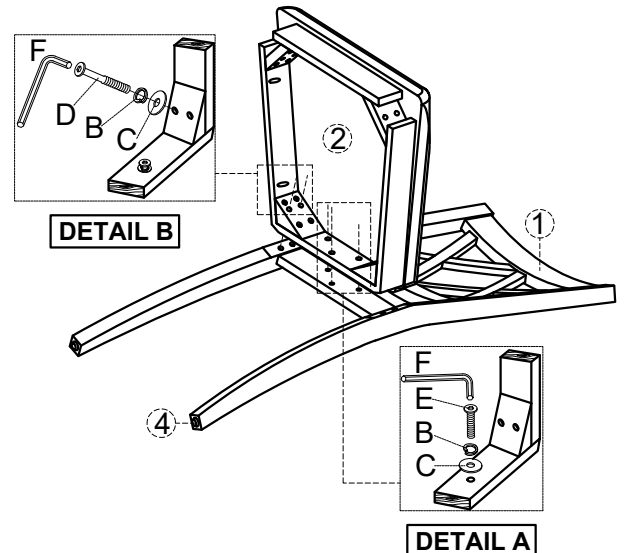
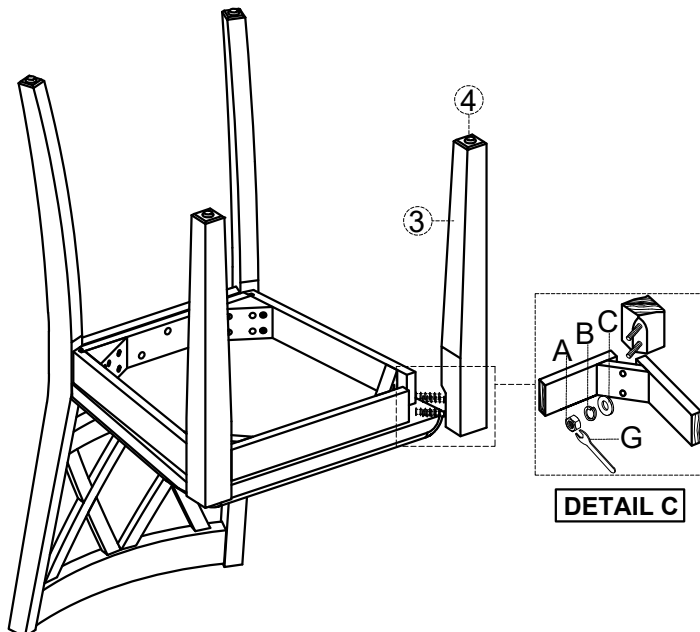

STEP 2

- Carefully turn chair upside down and attach each Leg to the front corners of the Complete Seat. Place Flat Washer, Lock Washer and Nut on each leg bolt, tightening the Nut on each Leg using provided Key Wrench. (See Detail C).
- Be sure to level the chair prior to tightening all the nuts/screws.

