





Thank you for purchasing this quality product. Be sure to check all packing material carefully for small parts that may have come loose inside the carton during shipment.

Hardware kit (1790-3P01)			
No		Description	Q'Ty
A		Lock Washer Ø8	16 pcs
B		Flat Washer Ø8	16 pcs
C		Bolt Ø6 x 70mm	16 pcs
D		Allen Key	1 pc

Key Parts			
No	Code	Description	Q'Ty
1	1790-3P51	Storage Box	1 pc
2	1790-3P02	Table Leg	4 pcs
3	1790-3P08	Shelf	1 pc
4	1790-3P05	Drawer	1 pc
5	1790P04	Pull W/Screw	1 pc
6	1790P05A	Drawer Stop	1 pc
7	1790-3P06	Drawer glide	2 pcs
8	1790P01F	Floor glide	4 pcs

STEP 1

- Take Drawer out unit making sure that Drawer Stop (5) is in open position first. See (Detail A)

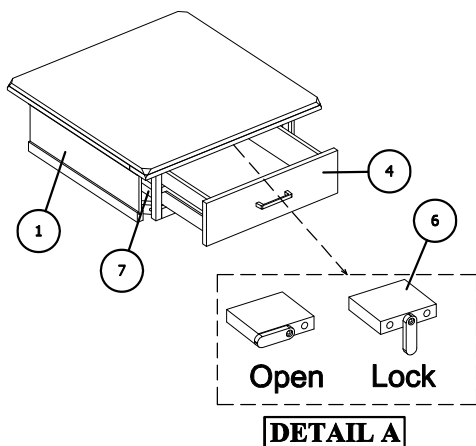

DETAIL A

STEP 2

- Carefully lay Table Top upside down on a smooth flat surface
- Attach each Leg to each corner of the Table Top as shown in illustration. Insert a Flat Washer(B) and Lock Washer(A) with Bolt(C) by turning clockwise using provided Allen Key but not fully tighten. See (Detail B)

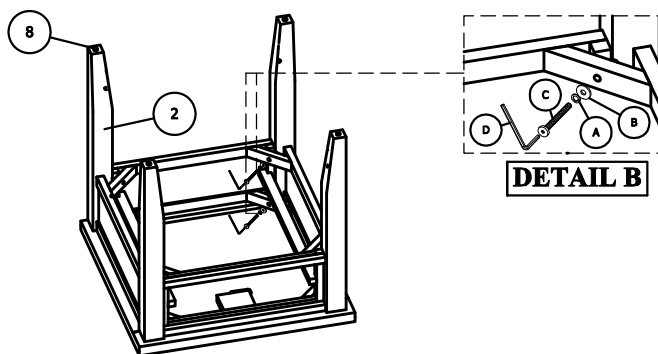

DETAIL B

STEP 3

- Attach each corner of the Shelf to each Leg as shown in illustration. Insert a Flat Washer(B) and Lock Washer(A) with Bolt(C) by turning clockwise using provided Allen Key fully tighten. See (Detail C)

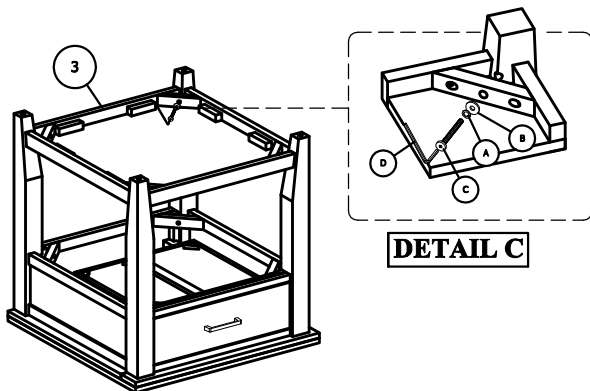

DETAIL C

STEP 4

- Insert Drawer into unit making sure that Drawer Stop is in open position first.
- After drawer has been inserted reposition Drawer stop so that it is in the locked position. See (Detail A)

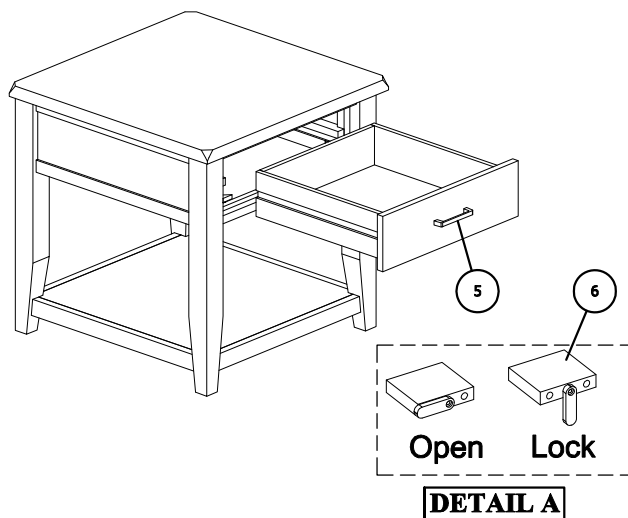

DETAIL A