

Thank you for purchasing this quality product. Be sure to check all packing material carefully for small parts that may have come loose inside the carton during shipment.

Hardware kit (1771-BS48KDP46)			
No		Description	Q'Ty
A		Hexa Nut Ø8	6 pcs
B		Lock Washer Ø8	16 pcs
C		Flat Washer Ø8	16 pcs
D		Long Bolt Ø6 x 80mm	4 pcs
E		Short Bolt Ø6 x 40mm	6 pcs
F		Allen Key	1 pc
G		Key Wrench	1 pc
H		Screw Ø64 x 35mm	10 pcs

Key Parts			
No	Code	Description	Q'ty
1	1771-BS48KDP40	Chair Back	1 pc
2	1771-BS48KDP41	Complete Seat	1 pc
3	1771-BS48KDP42	Right Facing Front Leg	1 pc
4	1771-BS48KDP43	Left Facing Front Leg	1 pc
5	1771-BS48KDP42M	Middle Leg	1 pc
6	1771-BS48KDP44	Right Facing Side Stretcher	1 pc
7	1771-BS48KDP45	Left Facing Side Stretcher	1 pc
8	1771-BS48KDP49M	Middle Stretcher	1 pc
9	1771-BS48KDP49	Front Stretcher	2 pcs
10	1771P01F	Floor glide	4 pcs

### STEP 1

- Carefully lay Chair Back flat on a smooth flat surface to prevent scratches.
- Attach Complete Seat to Chair Back by inserting a Flat Washer (C), Lock Washer (B) with Short Bolt (E) into each of the hole on the back rail of the seat, and Long Bolt (D), a Flat Washer (C) and Lock Washer (B) into each of 2 holes in the Complete Seat corners. (See Detail A & B).
- Tighten screws with provided Allen Key (F) by turning clockwise until secure

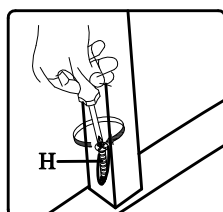

DETAIL C

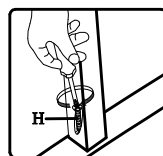

DETAIL C

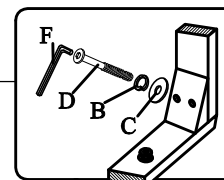

DETAIL B

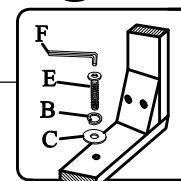
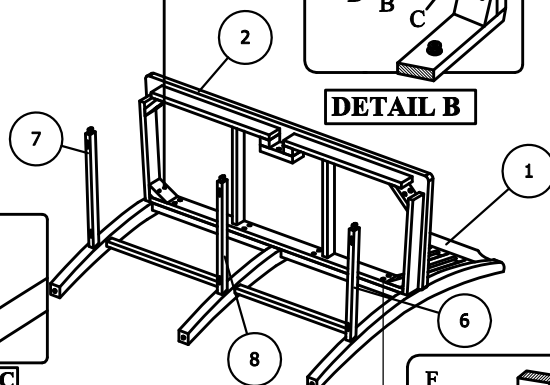

DETAIL A

### STEP 2

- Carefully turn chair upside down and insert the middle stretcher into the back middle leg, then position the middle front leg into the front middle block and connect the stretcher to the middle front leg. (See Detail E)
- Insert the left stretcher and right stretcher into the back left leg and back right leg, then position the front right and left legs into the corner block and connect the side stretcher to the front leg. (See Detail C)
- Insert the front stretchers between the middle and front legs. (See Detail C)
- Place Flat Washer (C), Lock Washer (B) and Nut (A) on each bolt, and hand tighten at this point
- Fasten stretchers with Wood Screws (H) by hand using a Phillips screwdriver (not provided) (See Detail C)
- Tighten all nuts by using Key Wrench (G)
- Be sure to tighten all screws and nuts prior to using Chair.

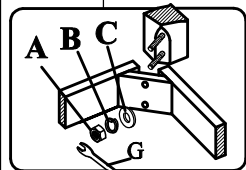
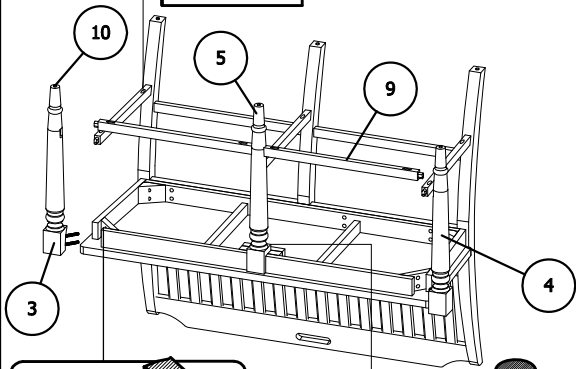

DETAIL D

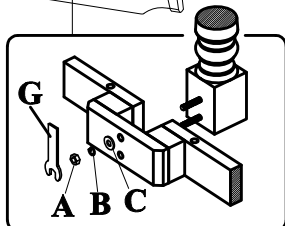

DETAIL E