





Thank you for purchasing this quality product. Be sure to check all packing material carefully for small parts that may have come loose inside the carton during shipment.

Hardware kit (1771-96P01)			
No		Description	Q'Ty
A		Lock Washer Ø8	8 pcs
B		Flat Washer Ø8	8 pcs
C		Nut ØM8	8 pcs
D		Key wrench	1 pc

Key Parts			
No	Code	Description	Q'Ty
1	1771-96P02	Table Leg - Corner	4 pcs
1A	1771-96P02M	Middle Table Leg	1 pc
2	1771-96P01A	Apron Spacer	6 pcs
3	1771P01F	Floor Glide	4 pcs
4	1771-96P13	Extension Mechanism	2 pcs
5	1771-96P13L	Extension Lock	6 pcs
6	1771-96P26	Corner Block	4 pcs
7	1771P01L	Floor Leveler	1 pc
8	1771-96P29	Mounting Board	1 pc

**NOTE:**

This table assembly requires two people

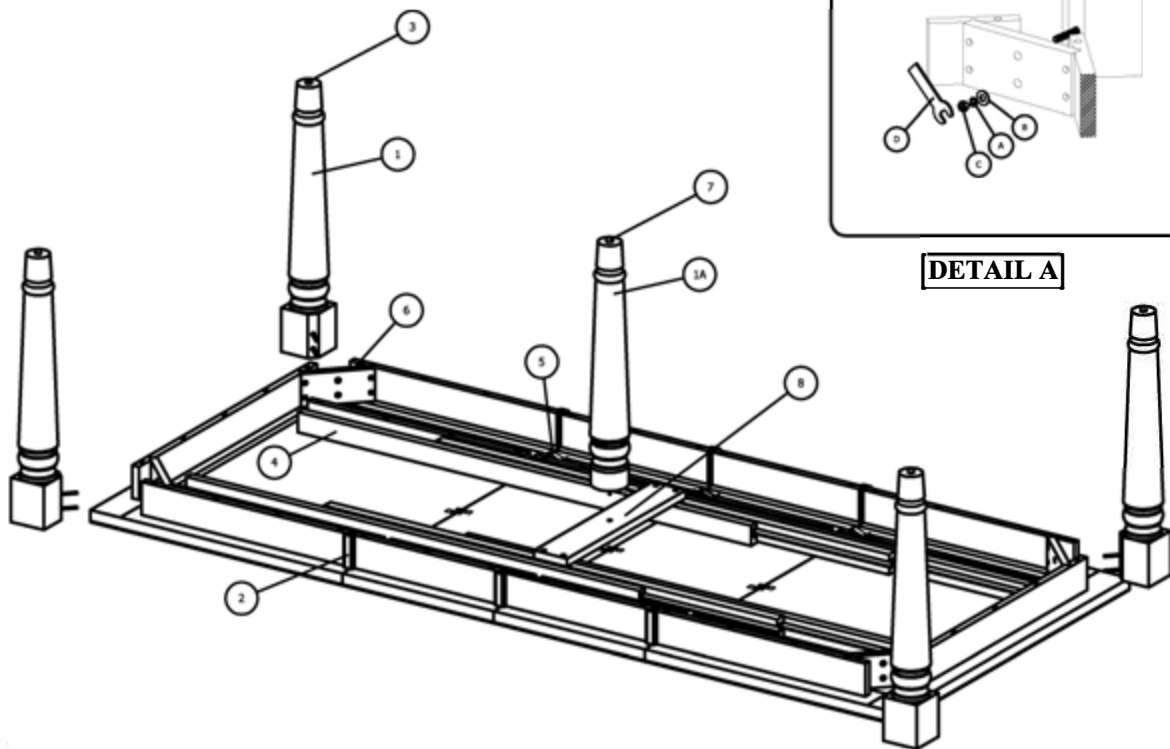

**STEP 1**

- Carefully lay Table Top upside down on a smooth flat surface to prevent scratches.
- Affix each Leg to each corner of the Table Top as shown in illustration. Insert a Flat Washer, Lock Washer and Nut on the bolts of each Leg (See Detail A)
- Once all Legs are in place, fully tighten nuts by turning clockwise using provided Key Wrench until secure.
- Attach the middle leg by screwing tightly into place and adjusting the leg leveler to meet the floor.

**PLEASE NOTE:**

- Two persons are required when opening and closing the table.
- Table must be lifted when moving to prevent stress on the middle leg.

