







Thank you for purchasing this quality product. Be sure to check all packing material carefully for small parts that may have come loose inside the carton during shipment.

Hardware kit (1700-420KDP46)			
No		Description	Q'Ty
A		Hexa Nut Ø8	4 pcs
B		Lock Washer Ø8.5	11 pcs
C		Flat Washer Ø8.5	11 pcs
D		Long Bolt Ø6.3 x 80mm	4 pcs
E		Short Bolt Ø6.3 x 38mm	3 pcs
F		Allen Key	1 pc
G		Key Wrench	1 pc

Key Parts			
No	Code	Description	Q'Ty
1	1700-420KDP40	Chair Back	1 pc
2	1700-420KDP41	Complete Seat	1 pc
3	1700-420KDP42	Front Leg	2 pc
4	1700-420KDP01F	Floor Glide	4 pcs

STEP 1

- Carefully lay Chair Back flat on a smooth flat surface to prevent scratches.
- Affix Complete Seat to Chair Back by inserting a Flat Washer, Lock Washer and Short K.D. Screw into each of the hole on the back of the seat. Tighten screws with provided Allen Key by turning clockwise until secure. (See Detail A).
- Insert a Flat Washer, Lock Washer and Long K.D. Screw into each of 2 holes in the Complete Seat corners. Tighten screws with provided Key Wrench. (See Detail B).

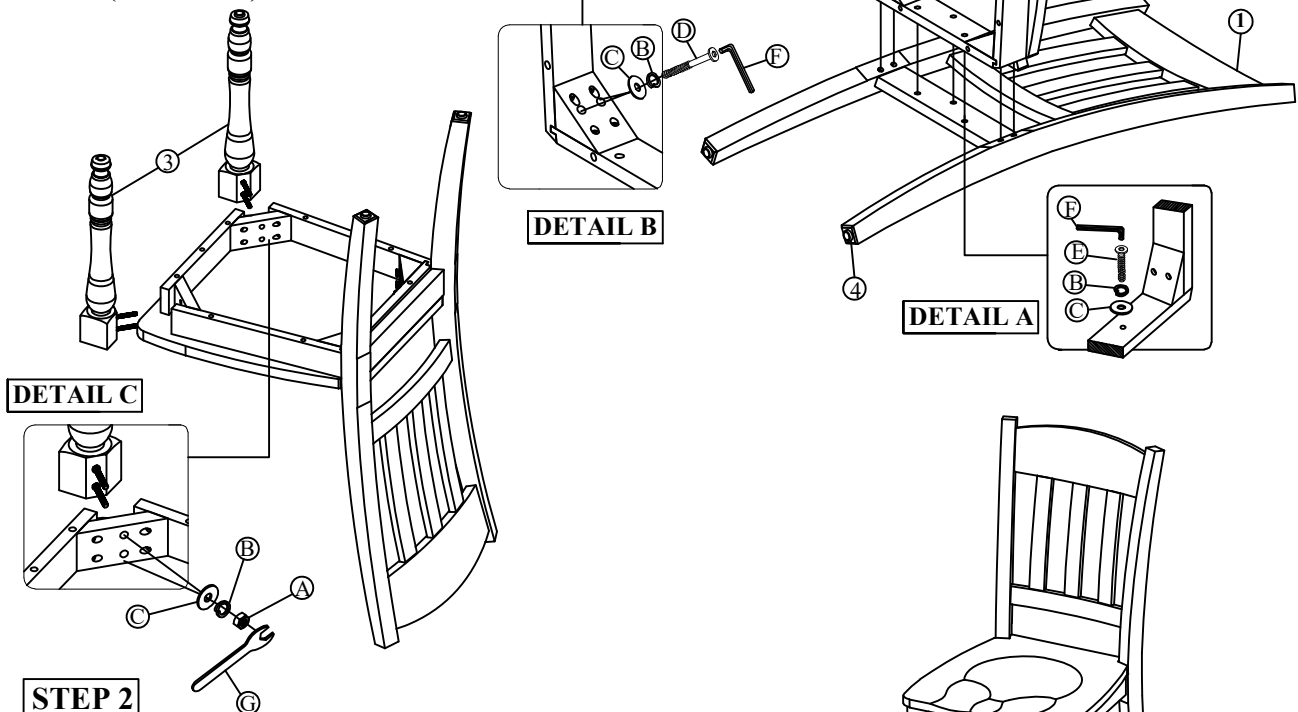

STEP 2

- Carefully turn chair upside down and affix each Leg to the front corners of the Complete Seat. Place Flat Washer, Lock Washer and Nut on each leg bolt, tightening the Nut on each Leg using provided Key Wrench. (See Detail C).
- Be sure to level the chair prior to tightening all the nuts/screws