





Thank you for purchasing this quality product. Be sure to check all packing material carefully for small parts that may have come loose inside the carton during shipment.

Parts key			
No	Code	Q'ty	Description
1	1700-3P51	1 Pc	Storage Box
2	1700-3P02	4 Pcs	Leg
3	1700-3P05	1 Pcs	Drawer Complete
4	1700-3P06	1 Pcs	Drawer Glide
5	1700-3P08	1 Pc	Shelf
6	1700P01F	4 Pcs	Floor Glide
7	1700P04	2 Pcs	Drawer Pull w/ Screw

Hardware Kit 1700-3P01			Q'ty
No	Description		Q'ty
A		Bolt Ø8 x 60	12 pcs
B		Lock washer Ø8.5	12 pcs
C		Flat washer Ø8.5	12 pcs
D		Allen key	1 pc

STEP 1:

- Carefully lay the Storage box upside down on a smooth flat surface to prevent scratches.
- Attach each Leg assembly to Storage box as shown in illustration.
- Insert a Bolt (A) with Flat washer (C), Lock washer (B) through holes in wood corner of Storage Box. Do not fully tighten.

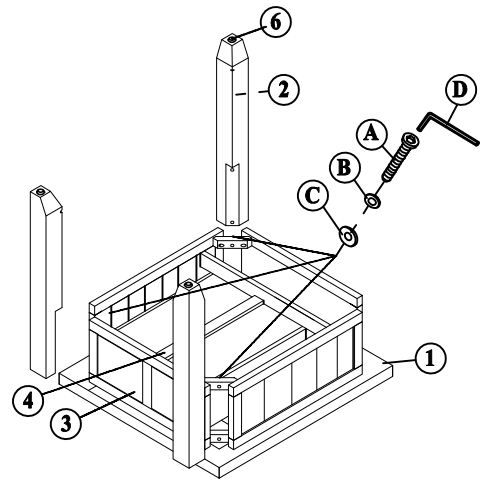

STEP 2:

- Insert the Shelf into designated locations as shown in illustration.
- Insert a Bolt (A) with Flat washer (C), Lock washer (B) through holes in wood corner of Shelf. Fully tighten all bolts with Allen key (D).
- Carefully turn End Table upright.

