







ASSEMBLY INSTRUCTIONS &
PARTS IDENTIFICATION
MODEL # 1670 - 3
END TABLE

Thank you for purchasing this quality product. Be sure to check all packing material carefully for small parts that may have come loose inside the carton during shipment.

Hardware Kit (1670P01)				Parts Key			
No.	Qty	Description		No.	Code	Qty	Description
A	8 pcs		Bolt M6 X 40mm	1	1570-3P53	2 pcs	Leg Assembly
B	8 pcs		Spring Washer				
C	8 pcs		Flat Washer				
D	1 pc		Allen key				

Step 1:

Turn the end table top upside down on a protective surface such as carpet or other soft material. Place the leg to the bottom apron. Insert the FLAT WASHER , SPRING WASHER and BOLT into pre-drilled holes on the apron and tighten it by using the Allen Key provided. Repeat for each leg.

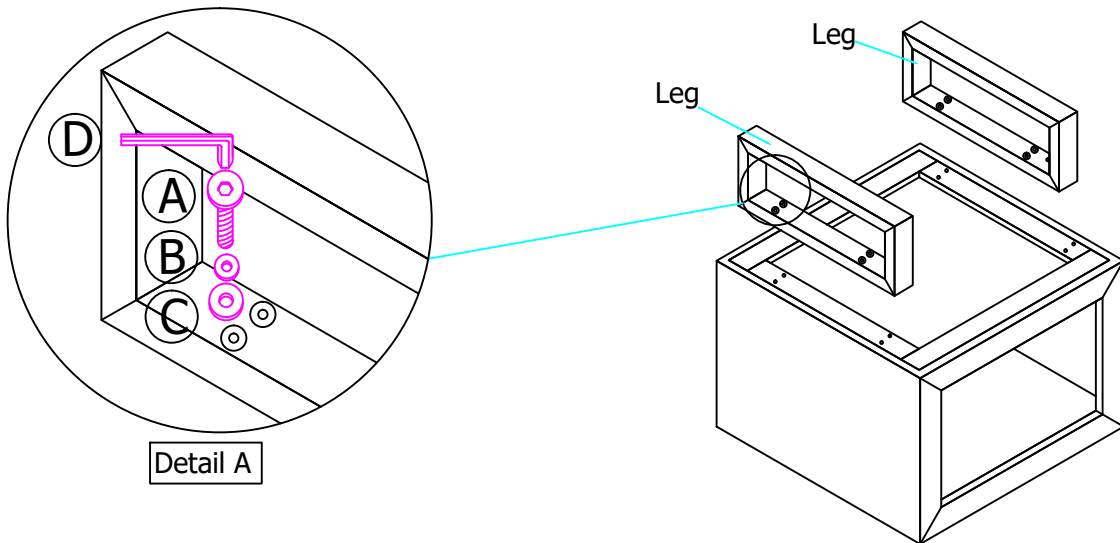

Step 2:

Set End Table upright on its legs.

