







Thank you for purchasing this quality product. Be sure to check all packing material carefully for small parts that may have come loose inside the carton during shipment.

Hardware Kit ( 1649-3P01 )			
No		Description	Qty
A		Bolt M6x50mm Sheft Bolt	6 Pcs
B		Bolt M6x40mm Top Bolt	10 Pcs
C		Lock Washer	16 Pcs
D		Flat Washer	16 Pcs
E		Allen key	1 Pc
F		Dowel	8 Pcs

Key Parts			
No	Code	Description	Qty
1	1649-3P51	STORAGE BOX	1 Pc
2	1649-3P53	LEG ASSEMBLY	2 Pcs
3	1649-3P08	SHELF	1 Pc
4	1649-3P05	DRAWER COMPLETE	1 Pc
5	1649-3P04	PULL W/ SCREW	1 Set
6	1649-3P06	FULL EXTENSION GLIDE	1 Set
7	1649-3P01F	FLOOR GLIDE	4 Pcs



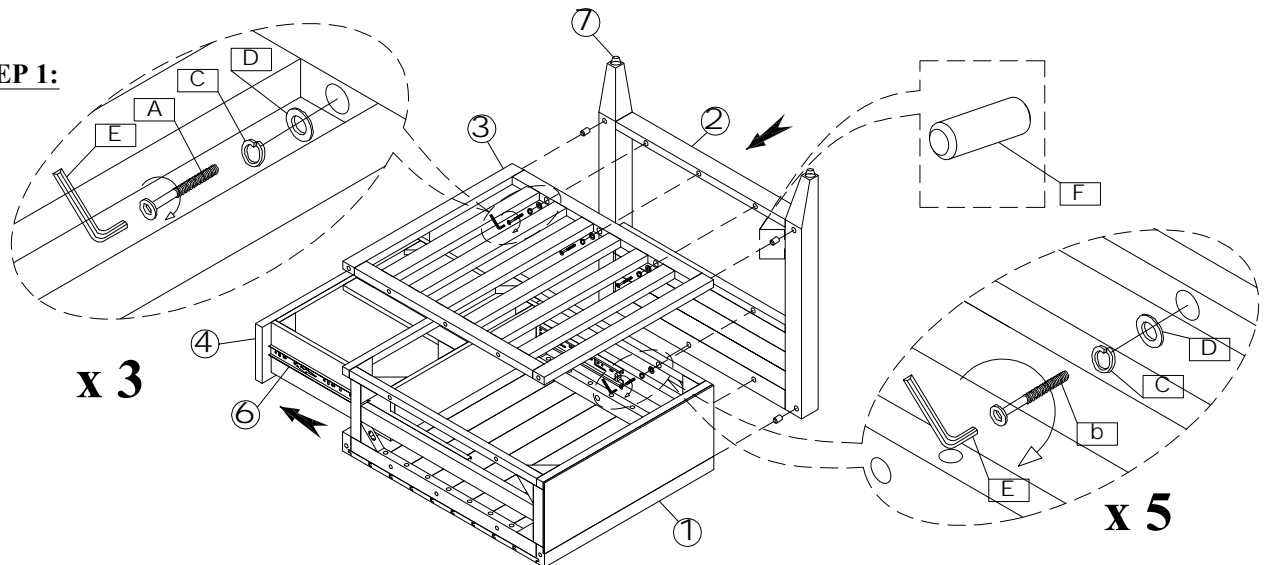

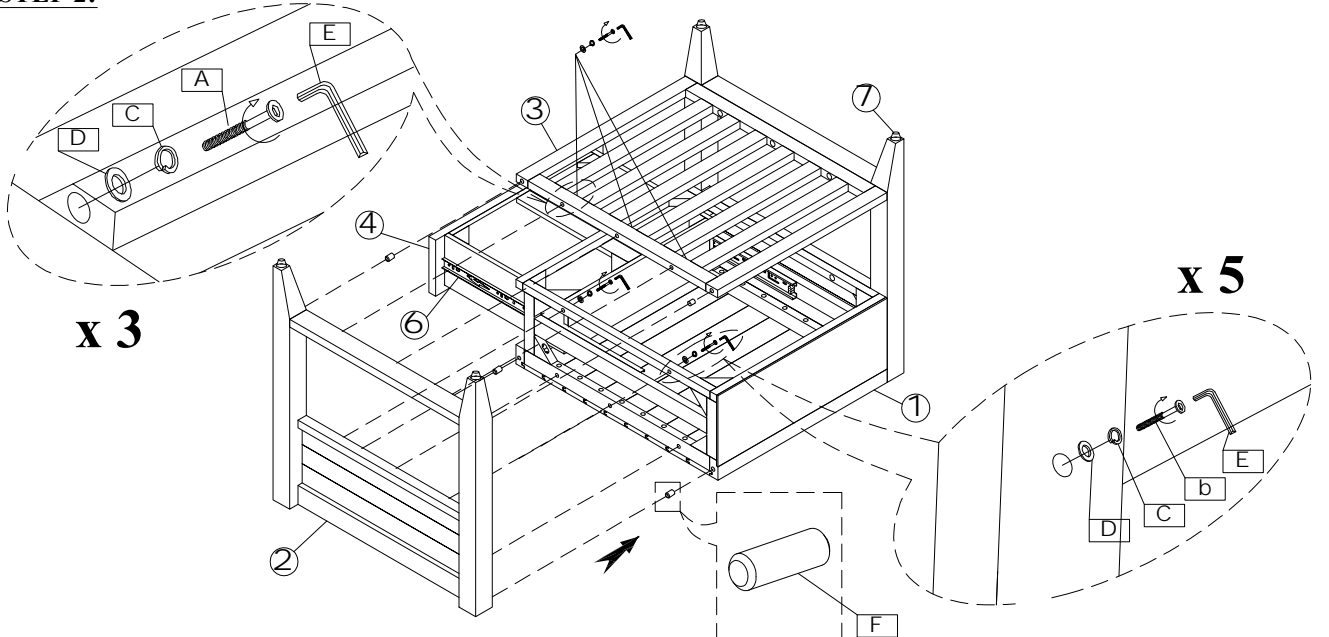

### STEP 1:



### STEP 2:



Thank you for purchasing this quality product. Be sure to check all packing material carefully for small parts that may have come loose inside the carton during shipment.

Hardware Kit ( 1649-3P01 )				Key Parts			
No	Description		Qty	No	Code	Description	Qty
A		Bolt M6x50mm Sheft Bolt	6 Pcs	1	1649-3P51	STORAGE BOX	1 Pc
B		Bolt M6x40mm Top Bolt	10 Pcs	2	1649-3P53	LEG ASSEMBLY	2 Pcs
C		Lock Washer	16 Pcs	3	1649-3P08	SHELF	1 Pc
D		Flat Washer	16 Pcs	4	1649-3P05	DRAWER COMPLETE	1 Pc
E		Allen key	1 Pc	5	1649-3P04	PULL W/ SCREW	1 Set
F		Dowel	8 Pcs	6	1649-3P06	FULL EXTENSION GLIDE	1 Set
				7	1649-3P01F	FLOOR GLIDE	4 Pcs

### STEP 3:

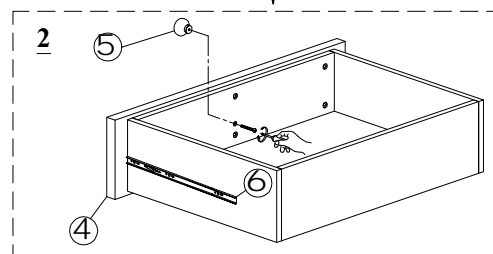
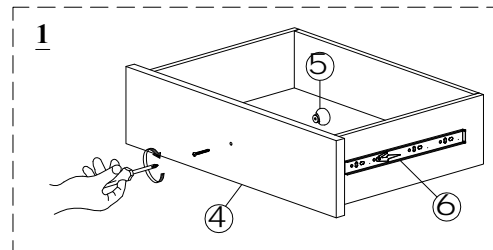
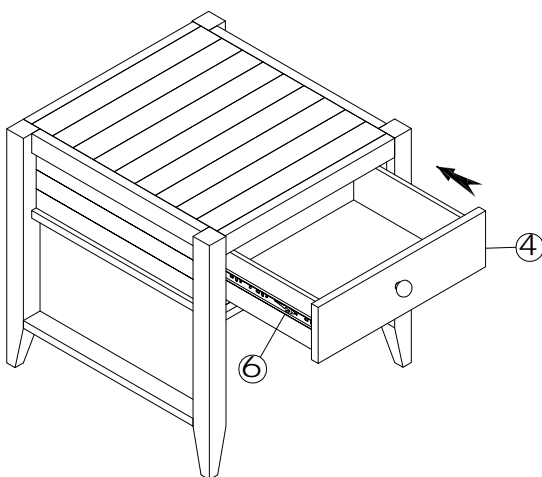

### STEP 4:

