









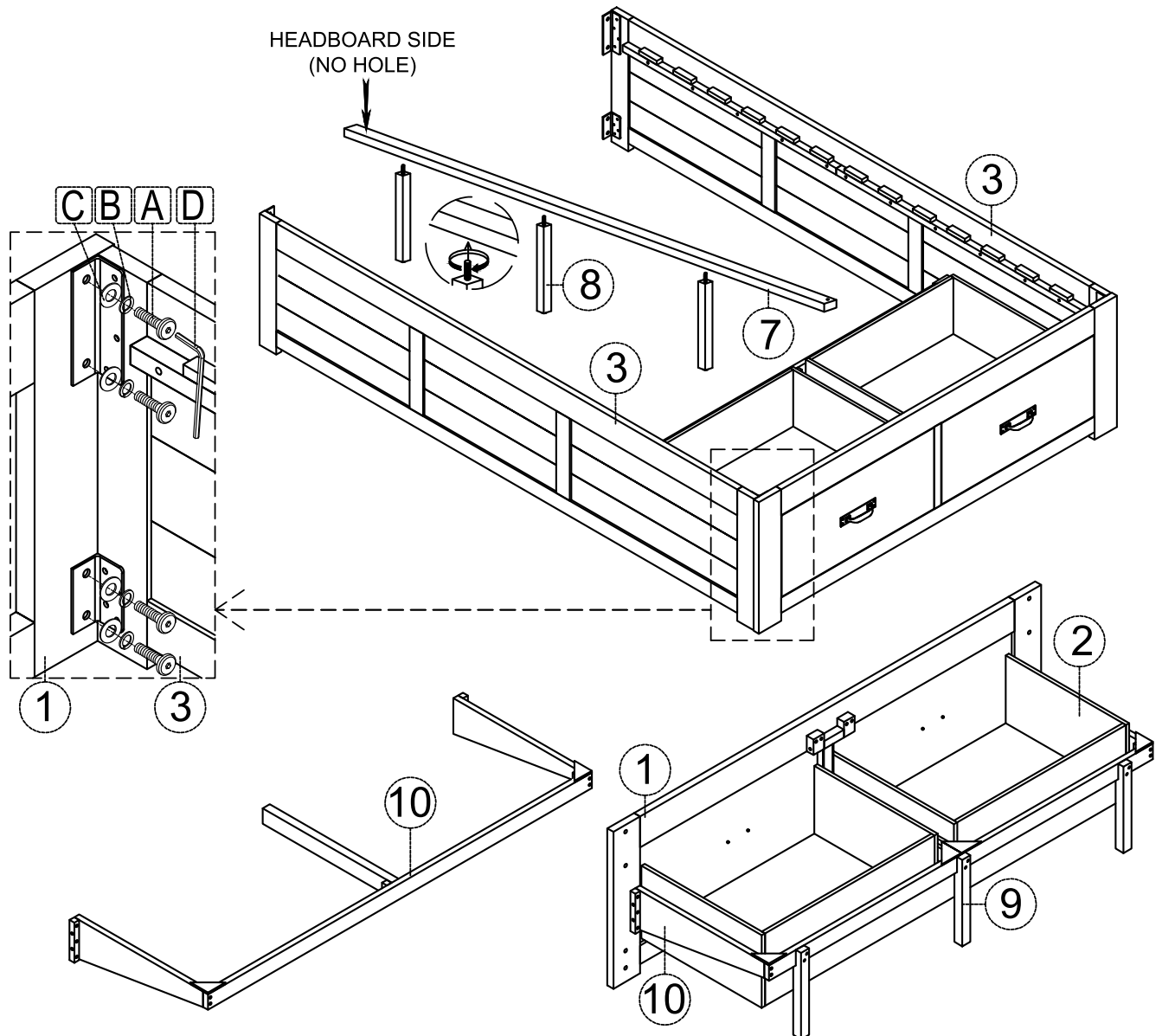

Thank you for purchasing this quality product. Be sure to check all packing material carefully for small parts that may have come loose inside the carton during shipment.

Parts key				Hardware kit #1605-87P01			
No	Code	Qty	Description	No	Description		Qty
1	1605-86	1 pc	Footboard	A		M8 x 20	8 pcs
2	1605-86P05	2 pcs	Footboard drawer	B		M8	8 pcs
3	1605-87	2 pcs	Side rails	C		M8 x 16	8 pcs
4	1605-86P11	13 pcs	Slats	D		K4	1 pc
5	1605P04	2 sets	Pull w/screws	E		M4 x 30	27 pcs
6	1605-86P06	2 sets	Full extension glide				
7	1605-87P11CS	1 pc	Center support				
8	1605-87P02C	3 pcs	Center leg				
9	1605-86P02D	3 pcs	Drawer support legs				
10	1605-86P05F	1 pc	Footboard drawer frame				



Thank you for purchasing this quality product. Be sure to check all packing material carefully for small parts that may have come loose inside the carton during shipment.

Parts key				Hardware kit #1605-85P01			
No	Code	Qty	Description	No		Description	Qty
11	1605-85	1 pc	Headboard	A		Bolt Headboard Legs M8 x 60	8 pcs
12	1605-85P02L	1 pc	Left Facing leg	B		Bolt Back Stretcher M6 x 35	4 pcs
13	1605-85P02R	1 pc	Right Facing leg	C		Bolt Side Rails M8 x 20	8 pcs
14	1605-85P11B	1 pc	Back Stretcher	D		Lock washer M8	20 pcs
				E		Flat washer M8 x 16	20 pcs
				F		Allen Key K4	1 pc

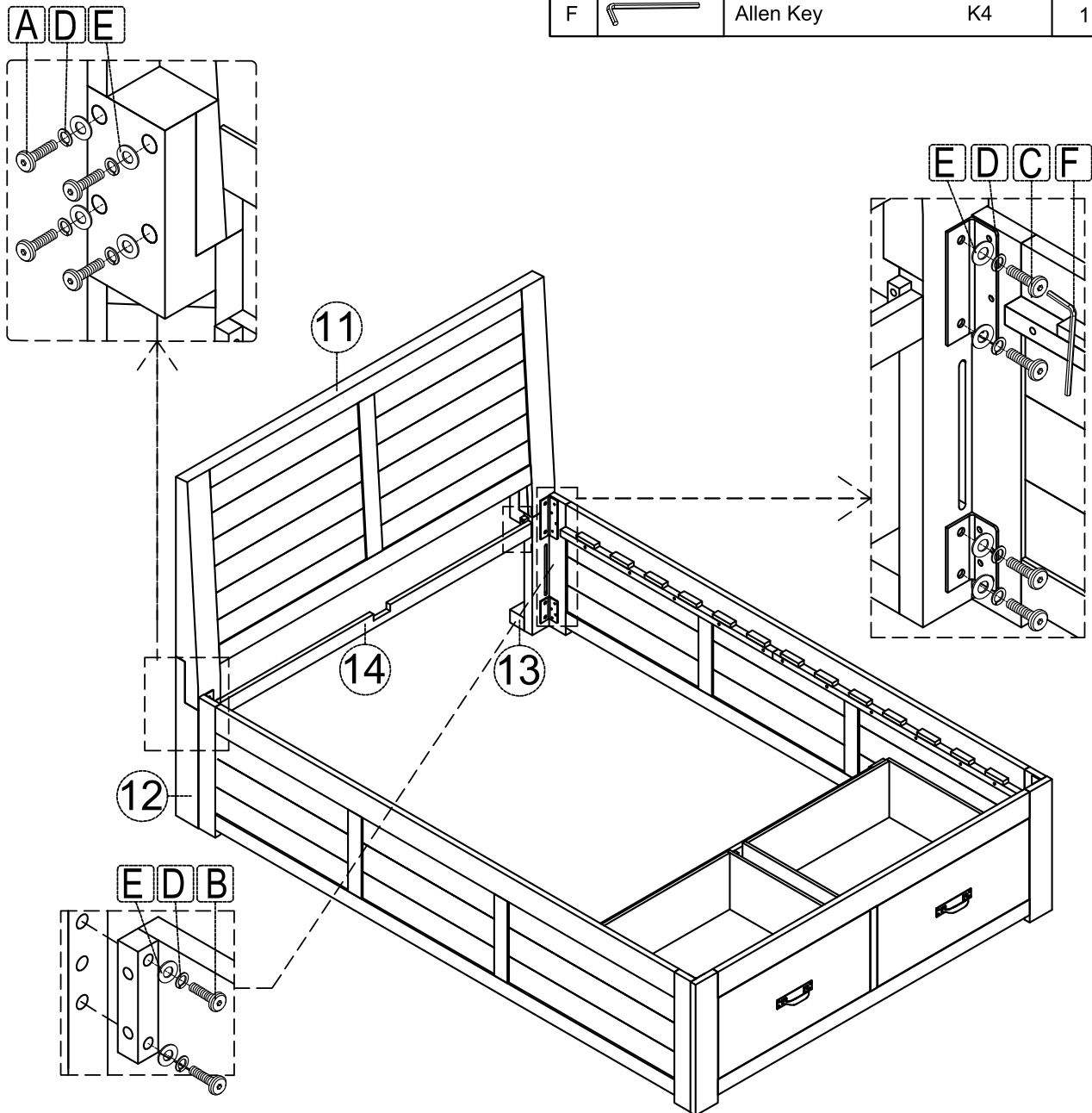

Thank you for purchasing this quality product. Be sure to check all packing material carefully for small parts that may have come loose inside the carton during shipment.

Parts key				Hardware kit #1605-87P01			
No	Code	Qty	Description	No	Description		Qty
1	1605-86	1 pc	Footboard	A	Bolt Side Rails	M8 x 20	8 pcs
2	1605-86P05	2 pcs	Footboard drawer	B	Lock washer	M8	8 pcs
3	1605-87	2 pcs	Side rails	C	Flat washer	M8 x 16	8 pcs
4	1605-86P11	13 pcs	Slats	D	Allen Key	K4	1 pc
5	1605P04	2 sets	Pull w/screws	E	Screw	M4 x 30	27 pcs
6	1605-86P06	2 sets	Full extension glide				
7	1605-87P11CS	1 pc	Center support				
8	1605-87P02C	3 pcs	Center leg				
9	1605-86P02D	3 pcs	Drawer support legs				
10	1605-86P05F	1 pc	Footboard drawer frame				

