

Thank you for purchasing this quality product. Be sure to check all packing material carefully for small parts that may have come loose inside the carton during shipment

Parts key				Hardware kit (#1510-13P01)			
No	Code	Qty	Description	No	Description		Qty
1		1 pc	End Table Top	A	Bolt	M8 x 40	8 pcs
2	1510-13P53	2 pcs	Leg Assembly	B	Lock washer	M8	8 pcs
3	1510-13P11	1 pc	Stretcher	C	Flat washer	M8 x 18	8 pcs
4	1510P01F	4 pcs	Floor Glide	D	Allen Key	K4	1 pc
5	1510-13P57	1 pc	Pullout Tray	E	Big hex nut	M18	2 pcs
				F	Large flat washer	Ø35	2 pcs
				G	Key Wrench	K27	1 pc
				H	Screw	Ø4 x 25	1 pc
				I	Stop for Pullout Tray	18 x 18 x 30	1 pc
				★ SCREW DRIVER (NEED - BUT NOT INCLUDED) 			

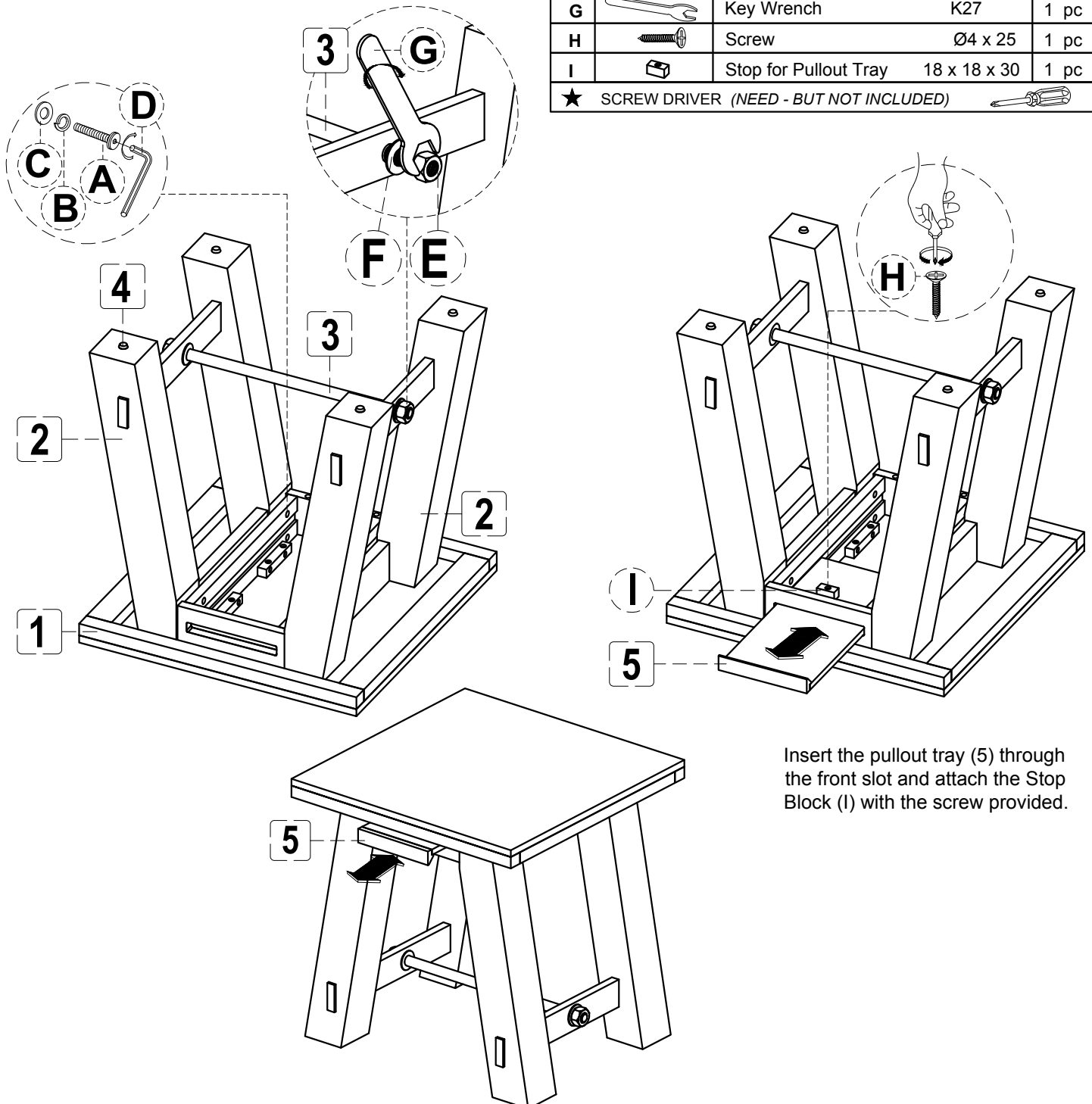

Insert the pullout tray (5) through the front slot and attach the Stop Block (I) with the screw provided.