

Hardware Kit (1037-4P01)

Ltr	Q'ty	Description	Size
A	1 pc	Allen wrench	4mm
B	8 pcs	Bolt	1/4"Dia*2"
C	8 pcs	Lock washer	1/4"Dia
D	8 pcs	Flat washer	1/4"Dia*3/4"
E	8 pcs	Screw	#8*1-1/2"

Part List

No.	Parts	Description	Q'ty
①	1037-4P02	Leg	4 pcs
②	1037-4P08	Shelf	2 pcs
③	1037-4P51	Storage Box	1 pc
④	1037-4P05	Drawer	2 pcs
⑤	1037P01F	Floor Glide	4 pcs
⑥	1037P04	Knobs/Screws	2 sets
⑦	1037P05A	Drawer Stopper	2 pcs
⑧	1037-4P06	Drawer Glide	2 pcs
⑨	1037P05D	Drawer support	2 pcs
⑩	1037P01AT	Anti Tip Kit	1set

STEP 3 : ▼

Insert the two shelves between the three legs and attach the fourth leg with a bolt, lock washer and flat washer.

Secure the shelf to the legs using screws(E). Once the shelf is in place fully tighten all bolts and screws.

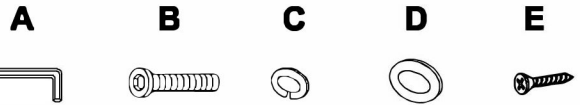
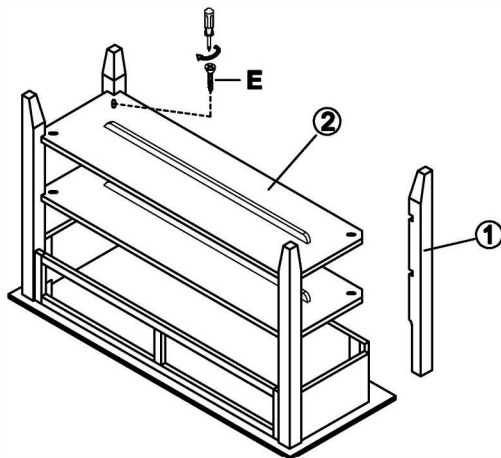

STEP 1 : ▼

First pull out the drawer, remove the drawer by pushing down on the plastic drawer stop and gently pulling out the drawer.

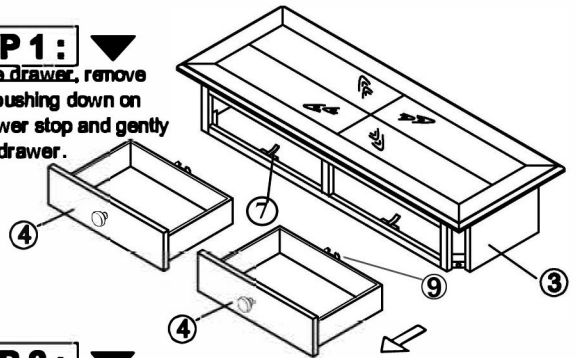

STEP 2 : ▼

Carefully place the table top upside down on a smooth, flat surface to prevent scratches during assembly. Attach three legs to the top with Allen Bolt (B), Lock Washer (C), and Flat Washer (D) loosely tightening with provided Allen Wrench (A). Do not completely tighten bolts at this point.

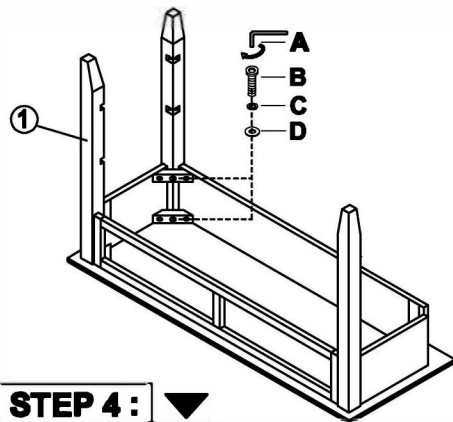

STEP 4 : ▼

Carefully turn the assembled table to the upright position. Put back the drawer. Attach the Anti-tip Over restraint. Assembly is now complete.

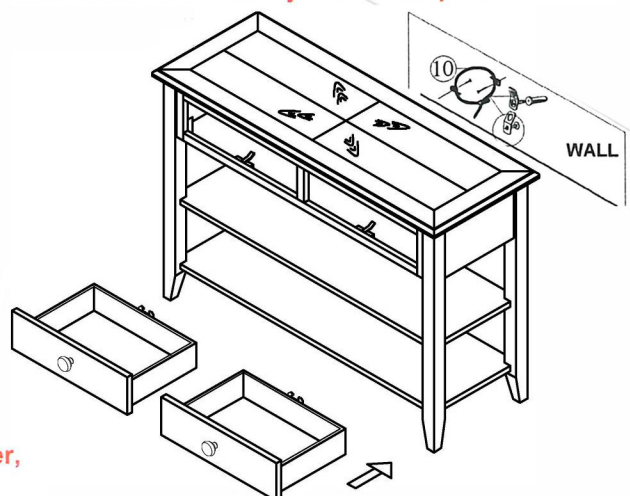

PLEASE NOTE: To help prevent the possibility of tip-over, install the ANTI - TIP OVER restraint provided

Made in Vietnam