

Hardware Kit (1032-7P01)

Ltr	Q'ty	Description	Size
A	1pc	Allen wrench	4mm
B	8pcs	Bolt	1/4"Dia*2"
C	8pcs	Lock washer	1/4"Dia
D	8pcs	Flat washer	1/4"Dia*19mm
E	4pcs	Screw	#8*1-1/2"

Wood Part List

No.	Parts	Description	Q'ty
①	1032-7P02	Leg	4pcs
②	1032-7P08	Shelf	1pc
③	1032-7P51	Storage Box	1pc
④	1032-7P05	Drawer	1pc
⑤	1032P01F	Floor Glide	4pcs
⑥	1032-7P04	Knobs/Screws	1pc
⑦	1032P05A	Drawer Stopper	1pc
⑧	1032-7P06	Drawer Glide	1pc
⑨	1032P05D	Drawer Support	1pc

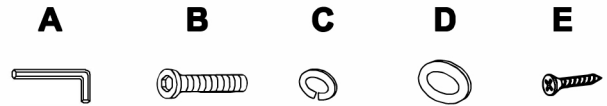

STEP 1 :

First pull out the drawer, remove the drawer by pushing down on the plastic drawer stop and gently pulling out the drawer"

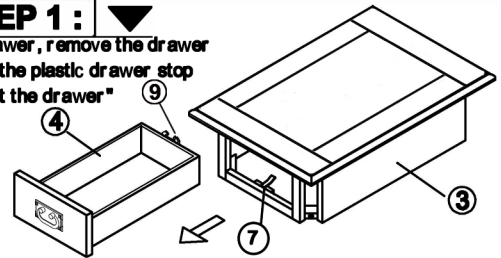

STEP 2 :

Carefully place the table top upside-down on a smooth, flat surface to prevent scratches during assembly. Attach three legs to the table top with Allen bolt (B), Lock washer (C) and Flat washer (D), loosely tightening with the provided Allen wrench (A). Do not completely tighten bolts at this point .

STEP 3 :

Insert the shelf between the three legs and attach the fourth leg with a bolt, lock washer and flat washer
Secure the shelf to the legs using screws (E)" Once the shelf is in place fully tighten all bolts and screws

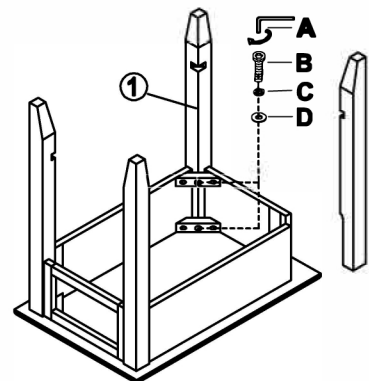
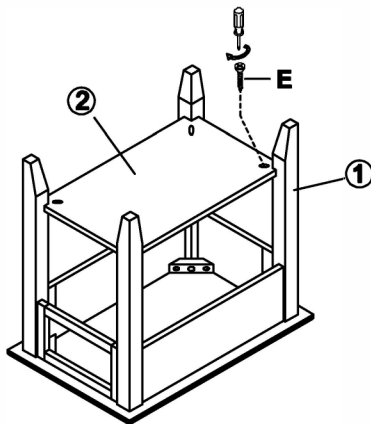

STEP 4 :

Carefully turn the assembled table the upright position, put back the drawer, assembly is now complete.

