

JOFRAN INC.

ASSEMBLY INSTRUCTIONS & PARTS IDENTIFICATION ITEM NO. : 1031-7 CHAIRSIDE TABLE

Hardware Kit (1031-7P01)

Ltr	Q'ty	Description	Size
A	1pc	Allen wrench	4mm
B	8pcs	Bolt	1/4"Dia*2"
C	8pcs	Lock washer	1/4"Dia
D	8pcs	Flat washer	1/4"Dia*19mm
E	4pcs	Screw	#8*1-1/2"

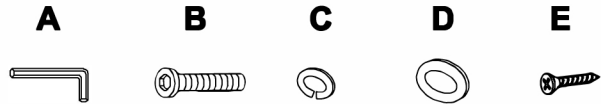

STEP 1:

First pull out the drawer, remove the drawer by pushing down on the plastic drawer stop and gently pulling out the drawer"

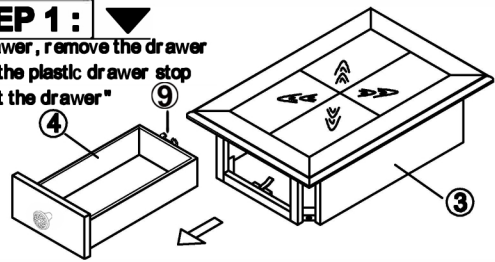

STEP 2:

Carefully place the table top upside-down on a smooth, flat surface to prevent scratches during assembly. Attach four legs to the table top with Allen bolt (B), Lock washer (C) and Flat washer (D), loosely tightening with provided Allen wrench (A). Do not completely tighten bolts at this point .

Wood Part List

No.	Parts	Description	Q'ty
①	1031-7P02	Leg	4pcs
②	1031-7P08	Shelf	1pc
③	1031-7P51	Storage Box	1pc
④	1031-7P05	Drawer	1pc
⑤	1031P01F	Floor Glide	4pcs
⑥	1031-7P04	Knobs/Screws	2pcs
⑦	1031P05A	Drawer Stopper	1pc
⑧	1031-7P06	Drawer Glide	1pc
⑨	1031P06D	Drawer support	1pc

STEP 3:

Insert the shelf between the three legs and attach the fourth leg with a bolt, lock washer and flat washer
Secure the shelf to the legs using screws (E)" Once the shelf is in place fully tighten all bolts and screws

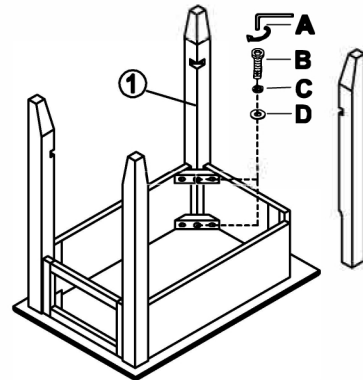
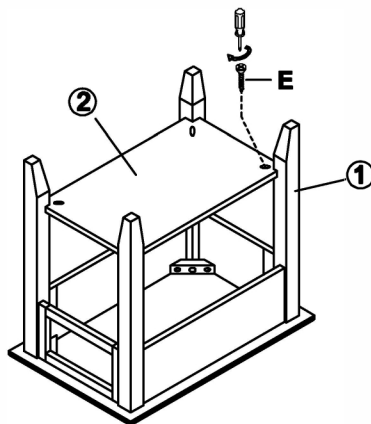

STEP 4:

Carefully turn the assembled table the upright position, put back the drawer, assembly is now complete.

